

Inductive sensor
BI10-G30-AZ3X-B1131

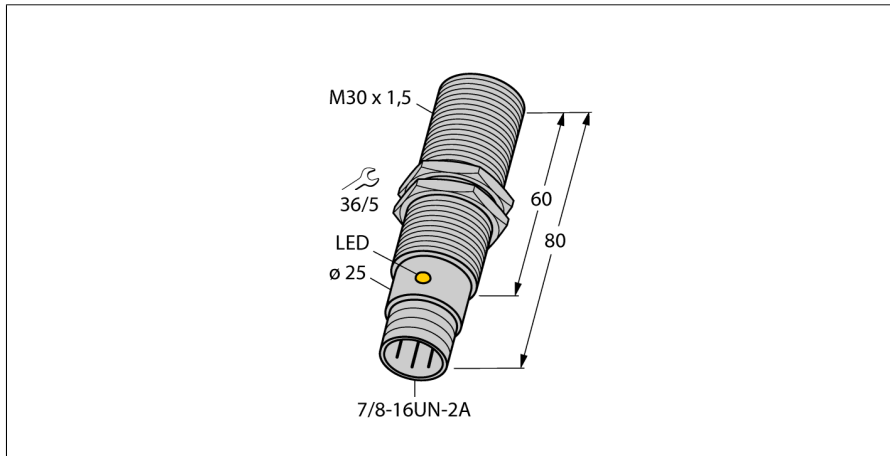

- Threaded barrel, M30 x 1.5
- Chrome-plated brass
- AC 2-wire, 20...250 VAC
- DC 2-wire, 10...300 VDC
- NO contact
- 7/8" connector

Wiring Diagram

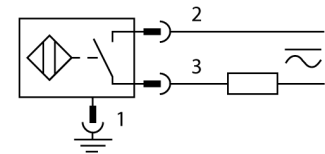

Functional principle

Inductive sensors detect metal objects contactless and wear-free. For this, they use a high-frequency electromagnetic AC field that interacts with the target. Inductive sensors generate this field via an RLC circuit with a ferrite coil.

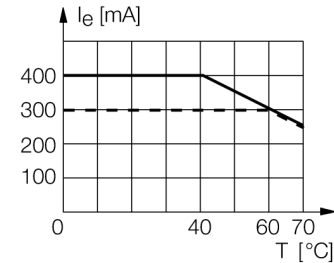

Type designation	BI10-G30-AZ3X-B1131
Ident-No.	43722
Rated switching distance Sn	10 mm
Mounting conditions	Flush
Secured operating distance	≤ (0,81 x Sn) mm
Correction factors	St37 = 1; Al = 0.3; stainless steel = 0.7; Ms = 0.4
Repeat accuracy	≤ 2 % of full scale
Temperature drift	≤ ± 10 %
Hysteresis	3...15 %
Ambient temperature	-25...+70 °C
Operating voltage	20...250VAC
Operating voltage	10...300 VDC
AC rated operational current	≤ 400 mA
DC rated operational current	≤ 300 mA
Frequency	≥ 50...≤ 60 Hz
Residual current	≤ 1.7 mA
Isolation test voltage	≤ 1.5 kV
Surge current	≤ 8 A (≤ 10 ms max. 5 Hz)
Voltage drop at I _e	≤ 6 V
Output function	2-wire, NO contact
Smallest operating current I _m	≥ 3 mA
Switching frequency	0.02 kHz
Design	Threaded barrel, M30 x 1.5
Dimensions	80 mm
Housing material	Metal, CuZn, Chrome-plated
Active area material	Plastic, PA12-GF30
Max. tightening torque housing nut	75 Nm
Electrical connection	Connector, 7/8"
Vibration resistance	55 Hz (1 mm)
Shock resistance	30 g (11 ms)
Protection class	IP67
MTTF	2283 years acc. to SN 29500 (Ed. 99) 40 °C
Switching state	LED, Red

Inductive sensor
BI10-G30-AZ3X-B1131

Distance D	2 x B
Distance T	3 x B
Diameter active area B	Ø 30 mm

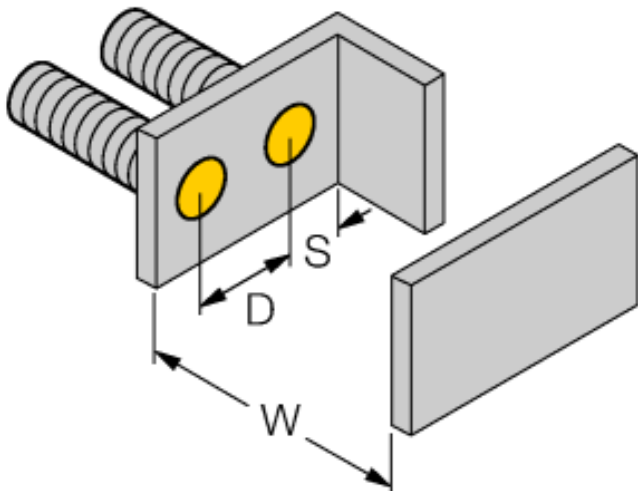
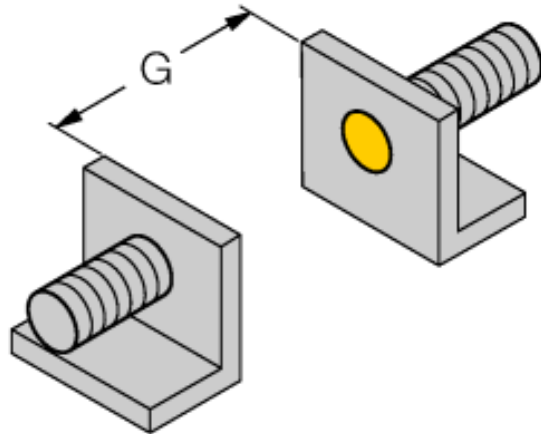
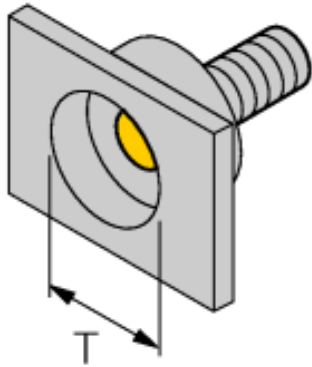

Inductive sensor
BI10-G30-AZ3X-B1131

Accessories

Type code	Ident-No.	Description	Dimension drawing
QM-30	6945103	Quick-mount bracket with dead-stop; material: Chrome-plated brass. Male thread M36 × 1.5. Note: The switching distance of the proximity switches may change when using quick-mount brackets.	
BST-30B	6947216	Mounting clamp for threaded barrel sensors, with dead-stop; material: PA6	
MW-30	6945005	Mounting bracket for threaded barrel sensors; material: Stainless steel A2 1.4301 (AISI 304)	
BSS-30	6901319	Mounting clamp for smooth and threaded barrel sensors; material: Polypropylene	