



WATERFLUX 3070 Technical Datasheet

IP68 Compact & remote
Battery powered electromagnetic water meter

- Battery power or optional mains power & battery backup with the FlexPower
- Easy installation without straight inlet or outlet lengths
- Integrated pressure and temperature sensor



1	Product features	4
1.1	The power of independence	4
1.2	Options	7
1.3	Measuring principle.....	10
2	Technical data	11
2.1	Technical data.....	11
2.1.1	Integrated P&T sensor (optional)	17
2.1.2	KROHNE FlexPower (optional)	18
2.1.3	Modbus protocol (option)	19
2.2	Legal metrology.....	20
2.2.1	OIML R49	20
2.2.2	MID Annex III (MI-001).....	23
2.2.3	Verification to MID Annex III (MI-001) and OIML R49	25
2.3	Measurement accuracy	26
2.3.1	WATERFLUX 3070 without straight inlet and outlet sections	27
2.4	Dimensions and weights	28
2.5	Pressure loss.....	30
2.6	Battery lifetime	31
3	Installation	32
3.1	General notes on installation	32
3.2	Intended use	32
3.3	Pre-installation requirements	32
3.4	General requirements	33
3.4.1	Vibration	33
3.4.2	Magnetic field.....	33
3.5	Installation conditions	34
3.5.1	Inlet and outlet	34
3.5.2	T-section	34
3.5.3	Open feed or discharge	34
3.5.4	Bends	35
3.5.5	Pump	35
3.5.6	Control valve	36
3.5.7	Air venting and vacuum forces	36
3.5.8	Mounting position and flange deviation.....	37
3.5.9	Installation in a metering pit and subsurface applications.....	38
3.6	Mounting	39
3.6.1	Torques and pressures.....	39
3.7	Mounting of the signal converter	42
3.7.1	Remote converter housing	42
3.7.2	Closing of the converter housing.....	43
4	Electrical connections	44
4.1	Safety instructions.....	44
4.2	Grounding	44

4.3 Cable overview.....	45
4.4 Connection of the sensor cable.....	46
4.5 Connection of the signal cable.....	47
4.5.1 IP68 housing (compact version).....	47
4.5.2 IP68 housing (remote version).....	48
5 Notes	50

1.1 The power of independence

In a world where water is becoming increasingly scarce, accurate flow measurements of a valuable resource like drinking water is essential for efficient water network management, reducing non-revenue water and for billing purposes. Throughout the history of the company, KROHNE has always been engaged in research into promising technologies for the future, in pursuit of improved measurement and further developments. WATERFLUX 3070, with its unique **rectangular sensor design** and efficient coil construction forms a good example of an innovation.

Flow profile disturbances are squeezed out by contraction and the mean flow velocity in the rectangular cross section is doubled. The coils provide a strong and homogeneous magnetic field, leading to an improved signal to noise ratio and stable measurements. The result is a very good low flow performance and a drastic reduction of the additional uncertainty for upstream disturbances. The WATERFLUX 3000 sensor has set a new standard in the market for simplifying installation with **zero inlet and zero outlet sections**. Another benefit of the rectangular bore is a very low power consumption and thus a longer battery lifetime.

The **battery powered** WATERFLUX 3070 is ideal for remote locations where **no mains power** is available. For locations where mains power is available, but water companies demand for a battery power back up to ensure continuous measurements, the WATERFLUX 3070 can be equipped with an external FlexPower unit.

Again KROHNE introduces an innovation with the introduction of the first all-in-one water meter that measures flow, pressure and temperature with just one instrument. For this the WATERFLUX sensor has an **integrated pressure and temperature sensor**.

To transfer all data, including counter values, pressure & temperature measurements and meter and status alarms, WATERFLUX 3070 can communicate by RS485 using the **Modbus RTU protocol**. The unique low (battery) powered Modbus option can be connected to a GPRS data logger unit for a complete remote solution. When using the **FlexPower unit**, with the high power Modbus version all available data is transferred at a high frequency.



1. Rectangular bore for DN25 up to DN600
2. Multiple power concept
3. Pulse and Modbus communication
4. Integrated pressure and temperature sensor

Highlights

Accurate and reliable performance

- Unique rectangular flow sensor design for sizes DN25...600
- Flow profile disturbances squeezed out by contraction
- Large turn down ratio for peak flows during the day and low flows during the night
- Standard in-house wet calibration for every meter
- Internal diagnostics and external verification with OPTICHECK tool

Approvals

- Certifications to OIML R49 and MID Annex III (MI-001) up to DN600
- Range of local custody transfer approvals based on OIML R49
- Drinking water approvals including ACS, DVGW, NSF, TZW and WRAS

Standard IP68 signal converter and sensor

- IP68 compact and field version for submersion in flooded chambers
- Compact housing with small footprint for installation in electrical cabinets
- Plug & play (IP68) connectors

Simplifies installation, minimises maintenance

- 0D inlet, 0D outlet for compact installation directly behind an elbow or reducer
- Special coating for immersed or subsoil sensor installation
- Standard reference electrode making grounding rings obsolete

Multiple power concept for any location

- Internal lithium batteries for battery lifetime up to 10 years
- External battery pack for longer lifetime
- AC mains supply and DC power (for green energy eg. solar or wind power) both with battery backup

Flow, pressure and temperature measurement

- Flow, pressure and temperature measurement integrated in one instrument
- Simple, cost efficient and tamper proof installation

Data communication and transfer

- RS485 Modbus RTU communication for disclosure of a wide range of data
- Special low power Modbus option for battery operation
- Preselected brands for GPRS/data logger for data transfer

Industries

- Water distribution network management
- District metering (DMA)
- Revenue metering
- Water abstraction
- Other; Irrigation, dewatering

Applications

- Measurement of clean potable water, raw water and irrigation water
- Monitoring of distribution networks
- Pressure and water quality control with integrated P&T sensor
- Pressure and pumping stations
- District Metering Areas (DMA) for leak detection
- Water consumption and billing
- Checking of water wells or pumps and maintaining water balance

1.2 Options



Remote or compact signal converter

The WATERFLUX 3070 is available in a compact or a remote (field) version.

The remote signal converter comes with a practical wall holder for easy mounting to a wall of a measurement chamber or electrical cabinet. The functionality of the compact and the remote version is identical.



Power: Internal or external battery pack

On locations where no power is available, the WATERFLUX 3070 is operated on batteries.

Standard the IFC 070 has an internal battery pack with lithium dual D-cell. For an extended battery lifetime an external battery pack with a lithium dual DD-cell can be connected to the converter. The KROHNE PowerBlock has a 1.5 meter cable.



FlexPower for mains power with battery backup

The WATERFLUX 3070 can be powered by an external IP68 rated **Flexpower unit** on locations with a main supply (110 V ... 230 V AC), but where battery backup is required. The integrated dual D-cell battery ensures a continuous measurement in cases where mains power supply is interrupted.

To save energy, the meter automatically switches to a low power battery backup mode. The FlexPower unit comes with a 10...30 V DC power cable for connection to green power supply sources such as wind or solar panels



Immersion in water (IP68)

Both sensor and signal converter are IP68 rated according IEC/EN 60529 suitable for immersing underwater during flooding (e.g. in periods of heavy rainfall).

The robust **WATERFLUX 3000** flow sensor is suitable for long duration immersion in flooded metering pits.

The compact and remote version of the IFC 070 signal converter, can be installed in chambers with periodic submersion.

The output cable has plug and play IP68 rated connectors. Immersion in water is possible down to a depth of 10 meters.



Underground installation

With its robust construction the flow sensor can also be buried underground. This can be a major cost saving as it eliminates the need for a measurement chamber. To protect the flow sensor a special coating can be ordered as an option. The remote sensor version has an IP68 stainless steel connection box.



Integrated Pressure & Temperature sensor

The **WATERFLUX 3070** is the first all-in-one water meter measuring flow, pressure and temperature with just one instrument. For this the WATERFLUX 3000 sensor is equipped with an integrated pressure and temperature sensor.

Flow, pressure and temperature values can be read on the display or via Modbus. When critical limits for pressure and temperature are exceeded an alarm can be generated via a status output or Modbus.

The integrated pressure and temperature sensor is available for sizes DN50 to DN200.



Calibration to OIML R49 and MID MI-001

Every single flowmeter is wet calibrated before leaving the factory. For this KROHNE operates a large number of accurate calibration facilities including the world's most precise volumetric calibration rig for flowmeters.

The WATERFLUX 3070 is approved to MID Annex III (MI-001) and OIML R49. The certification applies for accuracy class 1 and 2, all sizes, and for OD inlet- OD outlet. Access to fiscal parameters can be blocked to prevent intervention of non-authorized persons.



OPTICHECK | Tool for on-site verification

The OPTICHECK provides an inline health check of the meter under test. When the tool is connected on site, it gathers measuring data to ensure that the flowmeter is performing within 1% of its factory calibration. The baseline can be historic repair data from the factory or on-site test results after performing a full verification. A hard copy of the verification report can be printed for every flowmeter. The verification data are digitally stored. Contact KROHNE for more information or for an on-site service visit.

Data communication options

Water companies are looking for more measurement data, smart data, and real time data from water meters located over a wide area. The display forms the main source of data for meters subject to custody transfer (OIML R49, MI-001). Measurement and meter status data can be given out either via 2 pulse and 2 status outputs or via MODBUS RTU. Via its outputs the WATERFLUX 3070 can be connected to a wide range of data logger and remote communication equipment from various brands supporting pulses and or Modbus. Contact KROHNE for a list with preselected brands that have already been tested on their compatibility.



Modbus communication

The WATERFLUX 3070 offers two RS 485 Modbus RTU interface options. The low power (non-isolated) Modbus option can be used for data communication between a stand-alone battery operated WATERFLUX 3070 and data logger GPRS module. The high powered (isolated) Modbus option can be used for data transfer between a WATERFLUX 3070 using the FlexPower unit and process automation systems. Modbus offers a simple solution to disclose all available data including measurement data (sum, forward, reverse counters, flow rate), status data (battery lifetime, meter status) and actual values for pressure and temperature.

1.3 Measuring principle

An electrically conductive fluid flows inside an electrically insulated pipe through a magnetic field. This magnetic field is generated by a current, flowing through a pair of field coils.

Inside of the fluid, a voltage U is generated:

$$U = v * k * B * D$$

in which:

v = mean flow velocity

k = factor correcting for geometry

B = magnetic field strength

D = inner diameter of flowmeter

The signal voltage U is picked off by electrodes and is proportional to the mean flow velocity v and thus the flow rate Q . A signal converter is used to amplify the signal voltage, filter it and convert it into signals for totalizing, recording and output processing.

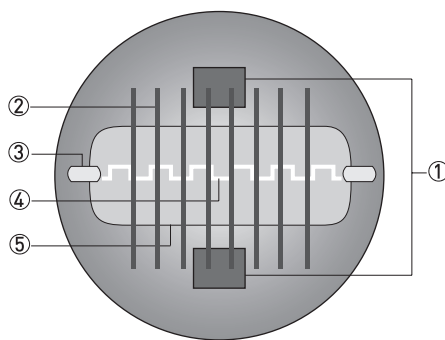

Figure 1-1: Measuring principle

- ① Field coils
- ② Magnetic field
- ③ Electrodes
- ④ Induced voltage (proportional to flow velocity)
- ⑤ Rectangular cross section

Rectangular cross section

The minimal height of the measuring tube decreases the distance between the field coils (1), resulting in a stronger and more homogeneous magnetic field (2). In addition, the mean flow velocity v increases due to the rectangular and reduced cross section. The large electrode spacing (D) and the increased flow velocity results in a higher magnetic signal voltage, also in the presence of a low flow rate.

2.1 Technical data

- The following data is provided for general applications. If you require data that is more relevant to your specific application, please contact us or your local sales office.
- Additional information (certificates, special tools, software,...) and complete product documentation can be downloaded free of charge from the website (Downloadcenter).

Measuring system

Measuring principle	Faraday's law of induction
Application range	Electrically conductive fluids
Measured value	
Primary measured value	Flow velocity
Secondary measured value	Volume flow
Optional measured value	Pressure and temperature

Design

Features	Unique rectangular flow tube design providing improved flow profile and signal to noise ratio resulting in highest accuracy, low energy consumption and large turndown ratio
	Rilsan® polymer coated flow tube approved for drinking water
	No internal or moving parts
	Built-in reference electrode
	Optional; built-in P&T sensor (restricted to DN50...200), refer to <i>Integrated P&T sensor (optional)</i> on page 17
	Self-providing energy by batteries for up to 10 years
Modular construction	The measurement system consists of a flow sensor and a signal converter. It is available as a compact and as a remote version.
Compact version	With IFC 070 converter: WATERFLUX 3070 C
Remote version	In field (F) version with IFC 070 converter: WATERFLUX 3070 F
	Cable length up to 25 m / 70 ft, other lengths on request
Nominal diameter	DN25...600 / 1...24", Rectangular bore
Display and user interface	
Display	LCD display, 8 digits
Operation	2 optical keys to navigate through the menu of the signal converter without opening the housing.
Display information	Standard:
	Sum counter (default), forward counter, reverse counter or flow rate
	Flow direction (forward or reverse), counter settings
	Measured value and measuring unit
	Battery lifetime indicator
Optional:	Operating pressure, operating temperature, empty pipe, self-test, display test, test mode, diameter, meter constant, software version, AMR mode, warning sign, multiplier
Remote reading	Optional: external GSM / GPRS data logger for pulse or Modbus For preselected data logger brands, please contact KROHNE

Measurements

Measuring units	Volume
	Default setting: m ³
	Selectable: liter, gallon, imperial gallons, cubic feet, acre inch, acre feet
	Flow rate
	Default setting: m ³ / hr
	Selectable: liter/sec, gallon/min, imperial gallon/min, cubic feet/hour, acre inch/day, acre feet/day
Measurement interval Battery power	Default setting: 15s
	Selectable: 5s, 10s, 15s, 20s
Measurement interval FlexPower	Default setting: 5s
Empty pipe detection	Optional: display shows - EP - in case of empty pipe detection
Low flow cut off	Measurements below this value are neglected
	Default setting: 10 mm/s
	Selectable: 0 mm/s, 5 mm/s, 10 mm/s

Measuring accuracy

Reference conditions	Medium: water
	Temperature: +10...30°C / +50...86°F
	Operating pressure: 1 bar / 14,5 psi
	Inlet section: 3 DN / Outlet section: 1 DN
Maximum measuring error	DN25...300; down to 0.2% of the measured value ± 1 mm/s DN350...600; down to 0.4% of the measured value ± 1 mm/s
	The maximum measuring error depends on the installation conditions.
	For detailed information refer to <i>Measurement accuracy</i> on page 26.
Repeatability	DN 25...300; $\pm 0.1\%$ ($v > 0.5$ m/s / 1.5 ft/s) DN350...600; $\pm 0.2\%$ ($v > 0.5$ m/s / 1.5 ft/s)
Calibration / Verification	Standard:
	2 Point calibration by a direct volume comparison.
	Optional: for DN25...600
	Verification to Measurement Instrument Directive (MID), Annex MI-001. Standard: Verification at Ratio (Q3/Q1) = 80 Optional: Verification at Ratio (Q3/Q1) > 80
MID Annex III (MI-001) (Directive 2014/32/EU)	EC-Type examination certificate to MID Annex III (MI-001)
	Diameter: DN25...600
	Minimum straight inlet flow: 0 DN
	Minimum straight outlet flow: 0 DN
	Forward and reverse (bi-directional) flow
	Orientation: any
	Ratio (Q3/Q1): up to 630
	Liquid temperature range: +0.1°C / 50°C
	Maximum operating pressure: \leq DN200: 16 bar, \geq DN250: 10 bar
	For detailed information refer to <i>Legal metrology</i> on page 20.

OIML R49	Certificate of conformity to OIML R49 (edition 2006)
	Diameter: DN25...600
	Accuracy: Class 1 and 2
	Minimum straight inlet flow: 0 DN
	Minimum straight outlet flow: 0 DN
	Forward and reverse (bi-directional) flow
	Orientation: any
	Ratio (Q3/Q1): up to 400
	Liquid temperature range: +0.1°C / 50°C
	Maximum operating pressure: ≤ DN200: 16 bar, ≥ DN250: 10 bar
For detailed information refer to <i>Legal metrology</i> on page 20.	

Operating conditions

Temperature	
Process temperature	-5...+70°C / +23...+158°F
Ambient temperature	-25...+65°C / -13...+149°F
	Ambient temperatures below -25°C / -13°F may affect the readability of the display.
	It is recommended to protect the converter from external heat sources such as direct sunlight because high temperatures reduce the life cycle of all electronic components and the battery.
Storage temperature	-30...+70°C / -22...+158°F
Measurement range	-12...12 m/s / -40...40 ft/s
Starting flow	From 0 m/s / 0 ft/s onwards
Pressure	
Operating pressure	Up to 16 bar (232 psi) for DN25...300 Up to 10 bar (150 psi) for DN350...600
Vacuum load	0 mbar / 0 psi absolute
Pressure loss	For detailed information refer to <i>Pressure loss</i> on page 30.
Chemical properties	
Physical conditions	Water: drinking water, raw water, irrigation water. For salt water, please contact the factory.
Electrical conductivity	≥ 20 μS/cm

Installation conditions

Installation	Assure that flow sensor is always fully filled.
	For detailed information refer to <i>Installation</i> on page 32.
Flow direction	Forward and reverse
	Arrow on flow sensor indicates forward flow direction.
Inlet run	≥ 0 DN
	For detailed information refer to <i>Measurement accuracy</i> on page 26.
Outlet run	≥ 0 DN
	For detailed information refer to <i>Measurement accuracy</i> on page 26.
Dimensions and weights	For detailed information refer to <i>Dimensions and weights</i> on page 28.

Materials

Sensor housing	Sheet steel
Measuring tube	DN25...200: metallic alloy
	DN250...600: stainless steel
Flanges	DN25...150 Stainless Steel 1.4404 (316L) DN200 Stainless Steel 1.4301 (304L) DN250...DN600 Steel St37-C22 / A105 Optional: DN250...DN600 Stainless Steel
Liner	Rilsan®
Protective coating	On exterior of the meter: flanges, housing, and / or connection box (field version)
	Standard: coating
	Option: subsoil coating
Measuring electrodes	Standard: stainless steel 1.4301 / AISI 304
	Optional: Hastelloy® C
Reference electrode	Standard: stainless steel 1.4301 / AISI 304
	Optional: Hastelloy® C
Grounding rings	Grounding rings can be omitted when the reference electrode is used.
Signal converter housing	Polycarbonate
Wall holder for remote signal converter	Polycarbonate
Connection box	Only for remote versions.
	Stainless steel

Process connections

EN 1092-1	Standard:
	DN25...200: PN 16
	DN250...600 : PN 10
	Optional:
	DN250...600: PN16 (DN350...600: 10 bar rated)
ASME	1...12": 150 lb RF (232 psi / 16 bar rated) 14...24": 150 lb (150 psi / 10 bar rated)
JIS	DN25...300 / 1...12": 10 K DN350...600 / 14"...24": 7,5 K
AS 4087	DN25...600 / 1"...24" : Class 16 on request (DN350...600 / 14"...24": 10 bar rated)
AS 2129	DN25...600 / 1"...24": Table D, E on request (DN350...600 / 14"...24": 10 bar rated)
For detailed information on nominal flange pressure and nominal diameter refer to <i>Dimensions and weights</i> on page 28.	
Other connections	
Thread	DN25: G1" thread connection
	DN40: G1.5" thread connection
Other	Weld-on, clamp, oval flanges: on request

Electrical connections

Cable connections		
Cable entries	IFC 070 C and F	
	Connection with 1 or 2 snap-on connectors	
Output cable	IFC 070 C and F	
	Standard: Pulse- or Modbus output cable.	
	Optional: Pulse output activated and connection to KGA 42 data logger - GPRS module. Output cable with 2 plug and play - IP68 rated connectors	
Power supply		
Battery	Standard:	
	Internal battery pack: Dual D-cell (Lithium, 3.6V, 38 Ah)	
	Optional:	
	External IP67 PowerBlock: Dual DD-cell (Lithium, 3.6V, 70 Ah), Cable length is 1.5 m	
KROHNE FlexPower Optional:	External IP68 rated AC/DC power supply (110...230V AC +/- 10% - 10..30V DC / 50-60Hz) with battery backup Dual D-cell (Lithium, 3.6V, 38 Ah). Cable length is 1.5 m	
Typical lifetime (default settings)	With 2 internal batteries;	DN25...200 : up to 10 years DN250...600 : up to 7 years
	With KROHNE PowerBlock;	DN25...200 : up to 16 years DN250...600 : up to 13 years
	For detailed information refer to <i>Battery lifetime</i> on page 31.	
Alarms	Pre-alarm at < 10% of its original capacity	
	Final alarm at < 1% of its original capacity	
Battery replacement	No loss of totalizer data	

Sensor cable (remote versions only)	
Type	KROHNE WSC2 standard cable, double shielded
Length	Standard: 5m
	Optional: 10m, 25m.
	Other cable lengths on request
In- and output	
Pulse output	2 Passive pulse outputs (maximum 3 outputs possible; see status output)
	$f \leq 100$ Hz; $I \leq 10$ mA; $U: 2.7...24$ VDC ($P \leq 100$ mW)
	Volume / pulse is programmable
	Phase shift between pulse A and B (forward and reverse) selectable
	Pulse width is selectable: 5 ms (default), 10 ms, 20 ms, 50 ms, 100ms, 200 ms
Status output	2 Passive status outputs (1 status output can be used as a third pulse output)
	$I \leq 10$ mA; $U: 2.7...24$ VDC ($P \leq 100$ mW)
	Function (selectable): pressure limit maximum, pressure limit minimum, temperature limit maximum, temperature limit minimum, self-check, battery pre warning, battery final warning, empty pipe
Communication	Internal & external batteries: Passive pulses or non-galvanic separated Modbus KROHNE FlexPower: Passive pulses or galvanic separated Modbus

Approvals and certificates

CE	
This device fulfils the statutory requirements of the EU directives. The manufacturer certifies successful testing of the product by applying the CE mark.	
	For full information of the EU directives & standards and the approved certifications, please refer to the CE declaration or the manufacturer website.
Custody transfer Not valid for integrated temperature and pressure sensor	Directive:2014/32/EU MID Annex III (MI-001) type examination certificate [DN25...600]
	OIML R49 edition 2006 certificate of conformity [DN25...600]
	* Innerstaatliche Bauartzulassung als Kaeltezaehler (For Germany, Switzerland and Austria).
	* NMI M10 Certificate of approval for accuracy class 2.5 (Australia)
	* DN40...100; SANS 1529 (South Africa)
	* Contact Product Support KROHNE
Other approvals and standards	
Drinking water approvals	ACS, DVGW W270, NSF / ANSI Standard 61, TZW, WRAS
Protection category according to IEC 60529	Compact (C) and field (F) version in polycarbonate housing: IP68 (NEMA 4X/6P) and IP68 FlexPower unit / IP67 External battery pack. [Test conditions; 1500 hours, 10 meters below surface]
Shock test	IEC 60068-2-27
	30 g for 18 ms
Vibration test	IEC 60068-2-64
	$f = 20 - 2000$ Hz, rms = 4.5g, t = 30 min.

2.1.1 Integrated P&T sensor (optional)

Design

Features	Optional: integrated pressure and temperature sensor in the WATERFLUX 3000 sensor.
	In combination with: IFC 070 (compact and remote) WATERFLUX 3000 sensor DN50...200

Measurements

Measuring range	Pressure
	-0.5...16 bar / -7.3...232 psi (relative)
	Temperature
	-5...+70°C / +23...158°F
Measuring units	
Pressure	Default setting: bar
	Selectable: mbar, psi
Temperature	Default setting: °C
	Selectable: °F
Measurement interval	Default setting: 15 min.
	Selectable: 1m, 5m, 10m, 15m or equal to the measurement flow interval.

Measuring accuracy

Maximum measuring accuracy	Pressure
	± 1% of full scale (0,5 ...16 bar / -7.3...232 psi) mm/s
	Temperature
	± 1,5°C for -5°...+70°C / +23...158°F

Materials

Pressure and temperature sensor	316L
---------------------------------	------

2.1.2 KROHNE FlexPower (optional)

Design

Features	The WATERFLUX 3070 can be connected to an external FlexPower unit. The input power for the FlexPower can be realized by connection to a AC/DC supply source
	Protection class ; IP68
	Housing material; Polypropylene

Operating range

Input	110...230 V AC $\pm 10\%$, 50-60 Hz, 9.5W
	10...30 V DC, 775-230 mA
Output	4.2 V DC, 5W
Cable (Output)	Combined power and output (Y-cable) with snap-on connector
Power Cable	DC cable (green) and AC cable (grey)
Temperature	
Storage and transport temperature	-30...+70°C / -22...158°F
Maximum operating temperature	-25°C ...+65°C / -13...149°F

Approval

Transport	Certificate under UN38.3 requirements (Transportation Tests for Lithium batteries)
Other approval and standards	
Protection category according to IEC 60529	KROHNE FlexPower: IP68 (NEMA 4X/6P) (Test conditions; 1500 hours, 10 meters below surface)
Shock test	IEC 60068-2-27
	30 g for 18 ms
Vibration test	IEC 60068-2-64
	f = 20 - 20000 Hz, rms = 4.5g, t = 30 min.

2.1.3 Modbus protocol (option)

The Modbus option on the WATERFLUX 3070 is available in two versions:

- not isolated (battery powered) - for standard internal battery version
- galvanically isolated (mains powered) - for KROHNE FlexPower version

The WATERFLUX 3070 flow converter and FlexPower with Modbus has a RS485 interface to communicate with an external device (PC or other suitable computer system) using the Modbus protocol. This option allows data exchange between PC or computer and single or multiple devices. The bus configuration consists of one external device as a master and one or more converters as slaves.

For bus operation, the device address, parity, baud rate, stop bits, data format and transmission delay must be set in the signal converter. All devices connected to the bus, must have the same baud rate and settings, but different (unique) addresses.

Please note that changing the baud rate will greatly affect the units battery life time. The baud rate equal to and below 9600 bps are considered energy efficient while baud rates greater than 9600 bps are not.

General technical data

Baud rate	1200, 2400, 3600, 4800, 9600 (default), 19200, 38400, 57600 or 115200
Protocol	Modbus RTU (documentation available on the Modbus Organisation website)
Data encoding	All Modbus data fields are encoded according to the IEC 61131-3 standard
Maximum participants on bus	32 per line, master included (may be extended by repeaters)
Coding	NRZ bit coding
Address range	Modbus: 1...247
Transmission procedure	Half duplex, asynchronous
Bus access	Master / slave
Device role	Slave
Cable	Shielded twisted pair for RS 485 applications
Distances	Isolated: Maximum 1.2 km / 3937 ft without repeater (dependent on baud rate and cable specifications) multi-drop
	Non isolated: Maximum 100 m, without termination (point to point)

For more details refer to the Modbus supplementary manual.

2.2 Legal metrology

2.2.1 OIML R49

The WATERFLUX 3070 has a certificate of conformity with the international recommendation OIML R49 (edition 2006). The certificate has been issued by NMi (Dutch board of weight and measures).

The OIML R49 recommendation (2006) concerns water meters intended for the metering of cold potable and hot water. The measuring range of the water meter is determined by Q3 (nominal flow rate) and R (ratio).

The WATERFLUX 3070 meets the requirements for water meters of accuracy class 1 and 2.

- For accuracy class 1, the maximum permissible error for water meters is ±1% for the upper flow rate zone and ±3% for the lower flow rate zones.
- For accuracy class 2, the maximum permissible error for water meters is ±2% for the upper flow rate zone and ±5% for the lower flow rate zones.

According to OIML R49, accuracy class 1 designation shall be applied only to water meters with $Q_3 \geq 100 \text{ m}^3/\text{h}$.

$$Q_1 = Q_3 / R$$

$$Q_2 = Q_1 * 1.6$$

$$Q_3 = Q_1 * R$$

$$Q_4 = Q_3 * 1.25$$

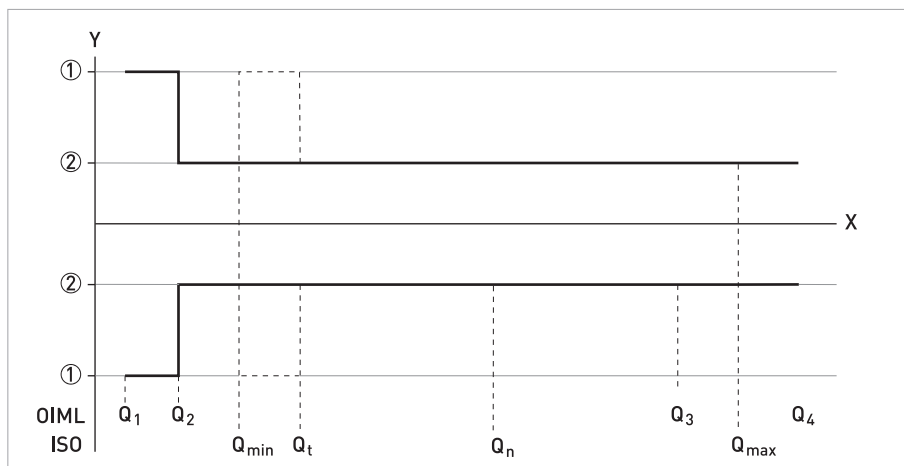

Figure 2-1: ISO flow rates added to figure as comparison towards OIML

X: Flow rate

Y [%]: Maximum measuring error

① ±3% for class 1, ±5% for class 2 devices

② ±1% for class 1, ±2% for class 2 devices

OIML R49 Class 1; certified metrological flow characteristics

DN	Span (R) Q3 / Q1	Flow rate [m ³ /h]			
		Minimum Q1	Transitional Q2	Permanent Q3	Overload Q4
65	250	0.400	0.64	100	125
80	250	0.640	1.02	160	200
100	250	1.00	1.60	250	312.5
125	250	1.60	2.56	400	500
150	250	2.52	4.03	630	787.5
200	160	3.9375	6.30	630	787.5
250	160	6.25	10.00	1000	1250
300	160	10.00	16.00	1600	2000
350	160	15.625	25.00	2500	3125
400	160	25	40.00	4000	5000
450	160	25	40.00	4000	5000
500	160	39.375	63.00	6300	7875
600	100	63	100.80	6300	7875

OIML R49 Class 2; certified metrological flow characteristics

DN	Span (R) Q3/Q1	Flow rate [m ³ /h]			
		Minimum Q1	Transitional Q2	Permanent Q3	Overload Q4
25	400	0.025	0.040	10	12.5
25	400	0.040	0.064	16	20.0
40	400	0.0625	0.100	25	31.3
40	400	0.100	0.160	40	50.0
50	400	0.100	0.160	40	50.0
50	400	0.1575	0.252	63	78.75
65	400	0.1575	0.25	63	78.75
65	400	0.250	0.40	100	125.0
80	400	0.250	0.40	100	125.0
80	400	0.400	0.64	160	200.0
100	400	0.400	0.64	160	200.0
100	400	0.625	1.00	250	312.5
125	400	0.625	1.00	250	312.5
125	400	1.000	1.60	400	500.0
150	400	1.000	1.60	400	500.0
150	400	1.575	2.52	630	787.5
200	400	1.575	2.52	630	787.5
250	400	2.500	4.00	1000	1250
300	400	4.000	6.40	1600	2000
350	160	15.625	25.0	2500	3125
400	160	25.000	40.0	4000	5000
450	160	25.000	40.0	4000	5000
500	160	39.375	63.00	6300	7875
600	160	63.000	100.80	6300	7875

2.2.2 MID Annex III (MI-001)

All new designs of water meters that are to be used for legal purposes in Europe require certification under the Measurement Instrument Directive (MID) 2014/32/EU Annex III (MI-001). Annex MI-001 of the MID applies to water meters intended for the measurement of volume of clean, cold or heated water in residential, commercial and light industrial use. An EC-type examination certificate is valid in all countries of the European Union.

The WATERFLUX 3070 has an EC-type examination certificate and can be verified to the MID Annex III (MI-001) for water meters with diameter DN25...DN600. The conformity assessment procedure followed for WATERFLUX 3070 is Module B (Type Examination) and Module D (Quality Assurance of the Production Process).

The maximum permissible error on volumes delivered between Q2 (transitional) flow rate and Q4 (overload) flow rate is $\pm 2\%$.

The maximum permissible error on volumes delivered between Q1 (minimum) flow rate and Q2 (transitional) flow rate is $\pm 5\%$.

Refer to the technical datasheet of WATERFLUX 3070 for further details of the certification.

$$Q1 = Q3 / R$$

$$Q2 = Q1 * 1.6$$

$$Q3 = Q1 * R$$

$$Q4 = Q3 * 1.25$$

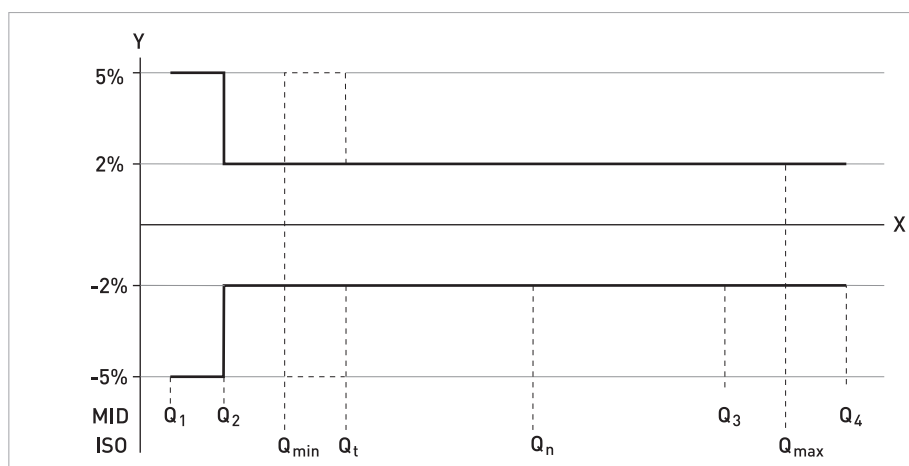

Figure 2-2: ISO flow rates added to figure as comparison towards MID

X: Flow rate

Y [%]: Maximum measuring error

MI-001 certified flow characteristics

DN	Span (R) Q3 / Q1	Flow rate [m ³ /h]			
		Minimum Q1	Transitional Q2	Permanent Q3	Overload Q4
25	640	0.025	0.040	16	20.0
40	640	0.0625	0.100	40	50.0
50	630	0.100	0.160	63	78.75
65	635	0.1575	0.252	100	125.0
80	640	0.25	0.400	160	200.0
100	625	0.40	0.640	250	312.5
125	640	0.625	1.00	400	500.0
150	630	1.00	1.60	630	787.5
200	508	1.575	2.52	800	1000
250	400	2.50	4.00	1000	1250
300	400	4.00	6.40	1600	2000
350	160	15.625	25.0	2500	3125
400	160	25.00	40.0	4000	5000
450	160	25.00	40.0	4000	5000
500	160	39.375	63.0	6300	7875
600	100	63.00	100.8	6300	7875

2.2.3 Verification to MID Annex III (MI-001) and OIML R49

Verification to MI-001 and to OIML R49 class 2 is carried out at the following values for R, Q1, Q2 and Q3. Verification to OIML R49 class 1 and at other values for R and Q3 available on request.

Verification to MID Annex III (MI-001)

DN	Span (R)	Flow rate [m ³ /h]		
		Q1	Q2	Q3
25	80	0.050	0.08	4
40	80	0.125	0.20	10
50	80	0.200	0.32	16
65	80	0.313	0.50	25
80	80	0.500	0.80	40
100	80	0.788	1.26	63
125	80	1.250	2.00	100
150	80	2.000	3.20	160
200	80	3.125	5.00	250
250	80	5.000	8.00	400
300	80	7.875	12.60	630
350	80	20.00	32.0	1600
400	80	31.25	50.0	2500
450	80	31.25	50.0	2500
500	80	50.00	80.0	4000
600	80	78.75	126	6300

2.3 Measurement accuracy

Each water meter is standard wet calibrated under reference conditions by direct volume comparison. The performance of the water meter is defined and documented in an individual water meter calibration certificate.

Reference conditions

- Medium: water
- Temperature: +10...+30°C / +50...+86°F
- Pressure: 1 bar / 14.5 psi
- Inlet section: ≥ 3 DN
- Outlet section: ≥ 1 DN

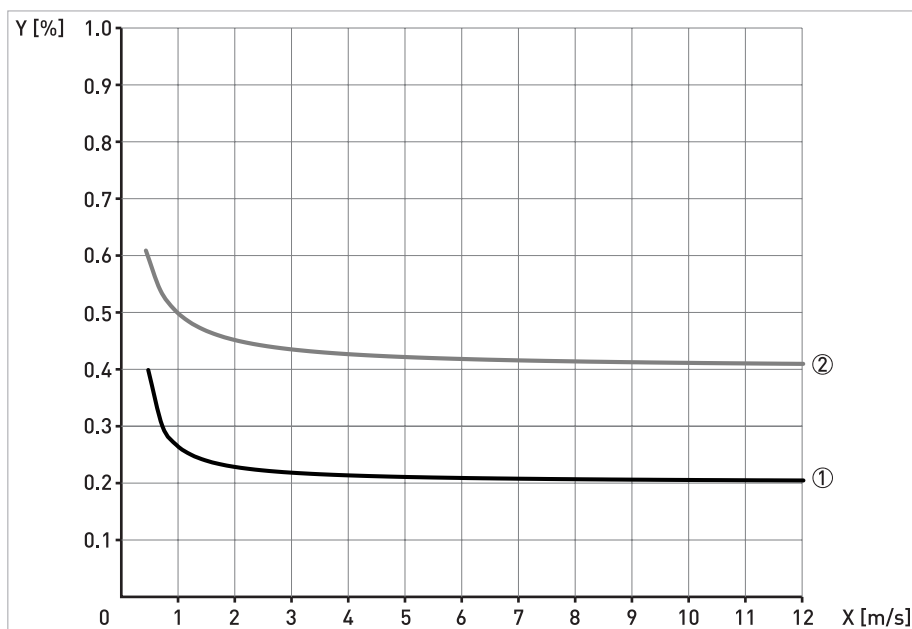

Figure 2-3: Measuring accuracy
X [m/s]: Flow velocity; Y [%]: Maximum measuring error

Accuracy with signal converter IFC 070

	Inlet	Outlet	Accuracy	Curve
DN25...300 / 1...12"	3 DN	1 DN	0.2% + 1 mm/s	①
DN350...600 / 14...24"	3 DN	1 DN	0.4% + 1 mm/s	②

2.3.1 WATERFLUX 3070 without straight inlet and outlet sections

Disturbed flow profiles, such as those that occur behind elbows, tee pieces, reducers or valves installed in front of a water meter, affect the measuring performance. Therefore it is usually recommended to fit a straight inlet length in front of and straight outlet length behind a water meter.

As a result of the unique WATERFLUX flow sensor design, whereby the mean flow velocity and flow profile are optimized within the rectangular and reduced cross section, the additional uncertainty for upstream disturbances are drastically reduced. Therefore the requirements for straight length and in front of and behind a meter are reduced.

The NMI has performed tests with various flow and swirl disturbers according to ISO 4064 and EN 14154. Based on these results the WATERFLUX 3070 has received a

OIML R49 certificate

- Diameter range DN25...600
- Accuracy class 1 and class 2
- Minimum straight inlet and outlet pipe length of 0 DN
- Bi-directional flow

EC-type certificate according MID Annex III (MI-001)

- Diameter range DN25...600
- Minimum straight inlet and outlet pipe length of 0 DN
- Bi-directional flow

2.4 Dimensions and weights

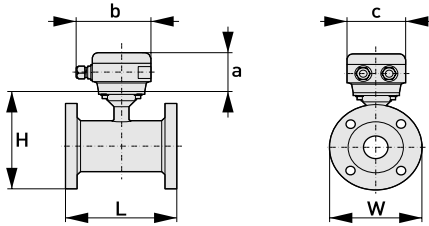
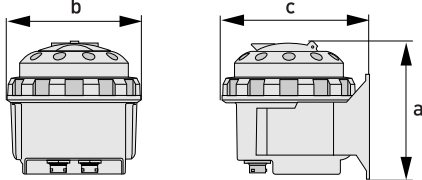
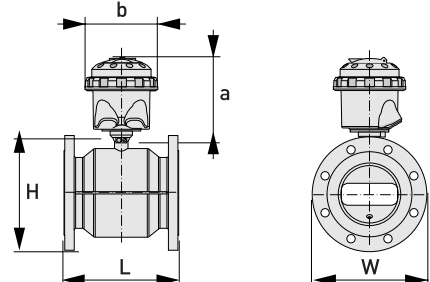
<p>Remote flow sensor</p>		<p>a = 88 mm / 3.5" b = 139 mm / 5.5" ① c = 106 mm / 4.2" Total height = H + a</p>
<p>Remote Signal converter in polycarbonate housing (IP68)</p>		<p>a = 171 mm / 6.7" b = 161 mm / 6.3" b = 177 mm / 7"</p>
<p>Compact version in polycarbonate housing (IP68)</p>		<p>a = 159 mm / 6.3" b = 161 mm / 6.3" Total height = H + a</p>

① The value may vary depending on the used cable glands.

- All data given in the following tables are based on standard versions of the flow sensor only.
- Especially for smaller nominal sizes of the flow sensor, the signal converter can be bigger than the flow sensor.
- Note that for other pressure ratings than mentioned, the dimensions may be different.
- For full information on signal converter dimensions see relevant documentation.

EN 1092-1

Nominal size DN [mm]	Dimensions [mm]			Approx. weight [kg]
	L	H	W	
25	150	151	115	5
40	150	166	150	6
50	200	186	165	13
65	200	200	185	11
80	200	209	200	17
100	250	237	220	17
125	250	266	250	21
150	300	300	285	29
200	350	361	340	36
250	400	408	395	50
300	500	458	445	60
350	500	510	505	85
400	600	568	565	110
450	600	618	615	125
500	600	671	670	120
600	600	781	780	180

ASME B16.5 / 150 lb

Nominal size [inches]	Dimensions [inches]			Approx. weight [lb]
	L	H	W	
1	5.91	5.83	4.3	18
1½	5.91	6	4.9	21
2	7.87	7.05	5.9	34
3	7.87	8.03	7.5	42
4	9.84	9.49	9.0	56
5	9.84	10.55	10.0	65
6	11.81	11.69	11.0	80
8	13.78	14.25	13.5	100
10	15.75	16.3	16.0	148
12	19.7	18.8	19.0	210
14	27.6	20.7	21	290
16	31.5	22.9	23.5	370
18	31.5	24.7	25	420
20	31.5	27	27.5	500
24	31.5	31.4	32	680

2.5 Pressure loss

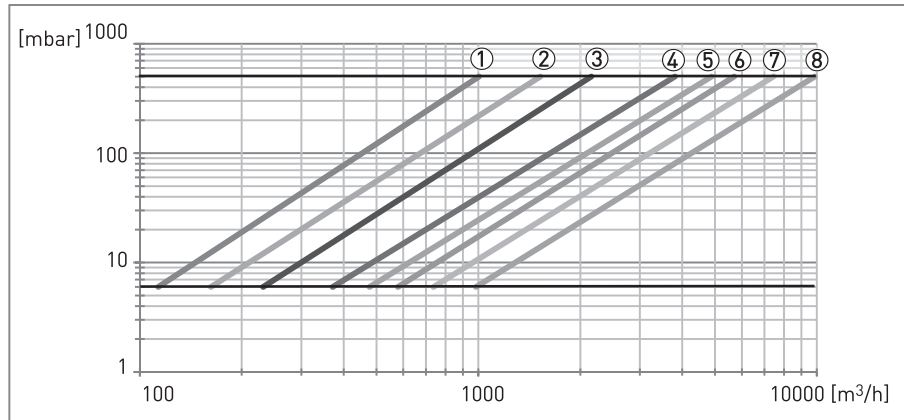

Figure 2-4: Pressure loss between 1 m/s and 9 m/s for DN25...150

- ① DN25
- ② DN40
- ③ DN50
- ④ DN65
- ⑤ DN80
- ⑥ DN100
- ⑦ DN125
- ⑧ DN150

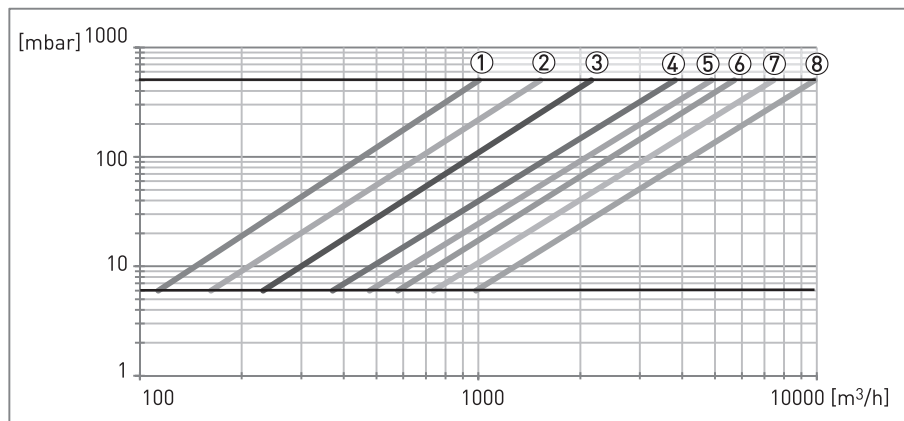

Figure 2-5: Pressure loss between 1 m/s and 9 m/s for DN200...600

- ① DN200
- ② DN250
- ③ DN300
- ④ DN350
- ⑤ DN400
- ⑥ DN450
- ⑦ DN500
- ⑧ DN600

2.6 Battery lifetime

The maximum battery lifetime depends on the choice of battery pack, the diameter and on the measurement interval. Other factors influencing the battery lifetime include the ambient temperature, the pulse output settings, the status output, the pulse width and the Modbus baud rate settings. The graphs show the battery lifetime for the different available battery types and measurement intervals.

Conditions

The maximum battery lifetime is based on default menu and Modbus settings, an ambient temperature of 25°C / 77°F and a flow rate at 2 m/s. The effect of the optional pressure and temperature sensor decreases the battery lifetime with 5% (on average).

Maximum lifetime of batteries for: DN25...200

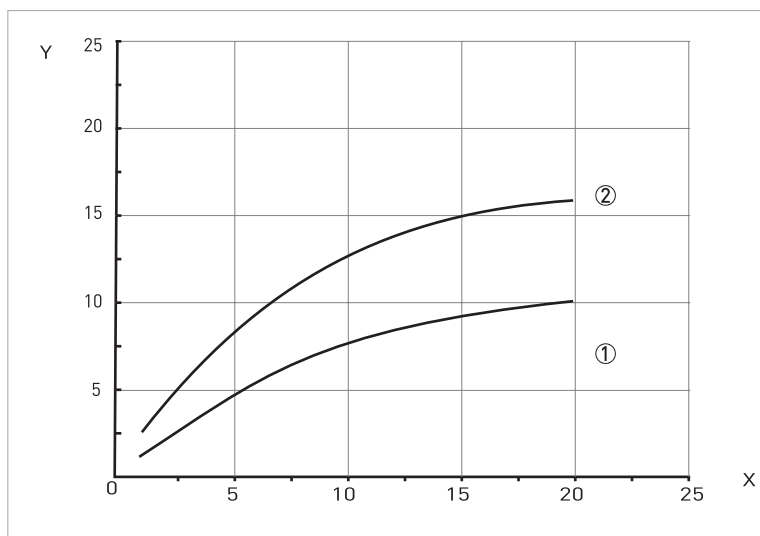

Figure 2-6: X = Measuring interval in seconds, Y = typical lifetime in years

Maximum lifetime of batteries for: DN250...600

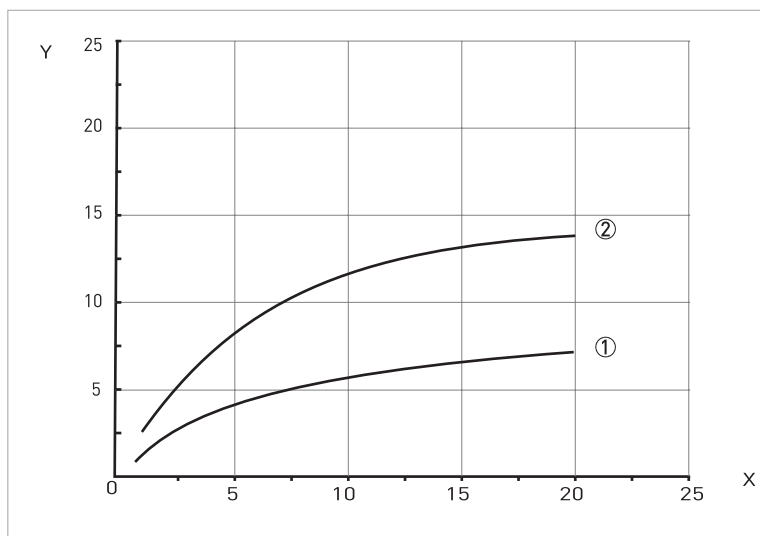

Figure 2-7: X = Measuring interval in seconds, Y = typical lifetime in years

- ① Intern Dual D-cell battery
- ② Extern KROHNE PowerBlock

3.1 General notes on installation

Inspect the packaging carefully for damages or signs of rough handling. Report damage to the carrier and to the local office of the manufacturer.

Do a check of the packing list to make sure that you have all the elements given in the order.

Look at the device nameplate to ensure that the device is delivered according to your order. Check for the correct supply voltage printed on the nameplate.

3.2 Intended use

Responsibility for the use of the measuring devices with regard to suitability, intended use and corrosion resistance of the used materials against the measured fluid lies solely with the operator.

The manufacturer is not liable for any damage resulting from improper use or use for other than the intended purpose.

This flowmeter is designed exclusively to measure the flow of drinking water and raw water.

If the device is not used according to the operating conditions (refer to chapter Technical data), the intended protection could be affected.

3.3 Pre-installation requirements

Make sure that you have all necessary tools available:

- Small screwdriver
- Wrench for cable glands (remote version only)
- Wrench for wall mounting bracket (remote version only)
- Torque wrench for installing flowmeter in pipeline

3.4 General requirements

The following precautions must be taken to ensure reliable installation.

- *Make sure that there is adequate space to the sides.*
- *Protect the signal converter from direct sunlight and install a sun shade if necessary.*
- *Signal converters installed in control cabinets require adequate cooling, e.g. by fan or heat exchanger.*
- *Do not expose the signal converter to intense vibration. The flowmeters are tested for a vibration level in accordance with IEC 68-2-64.*

3.4.1 Vibration

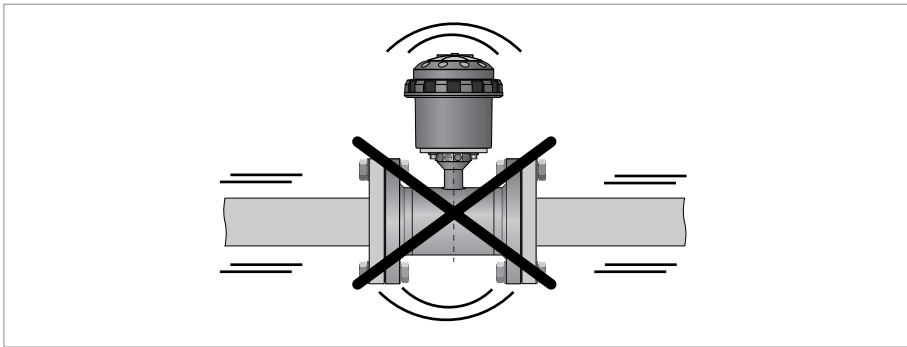

Figure 3-1: Avoid vibrations

3.4.2 Magnetic field

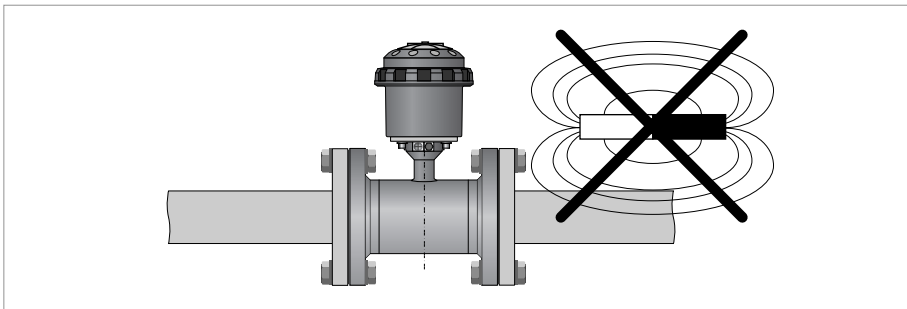

Figure 3-2: Avoid magnetic fields

3.5 Installation conditions

To prevent damage to the Rilsan® coating, the WATERFLUX 3000 sensor must be installed carefully. Take precautions during transport and installation to protect the in- and outlet of the sensor.

3.5.1 Inlet and outlet

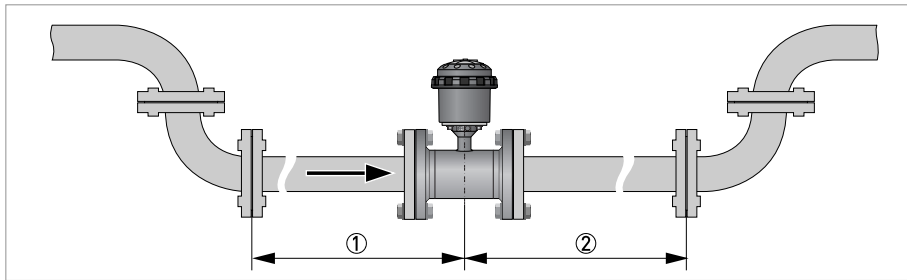

Figure 3-3: Minimal inlet and outlet

- ① Inlet: ≥ 0 DN
- ② Outlet: ≥ 0 DN

3.5.2 T-section

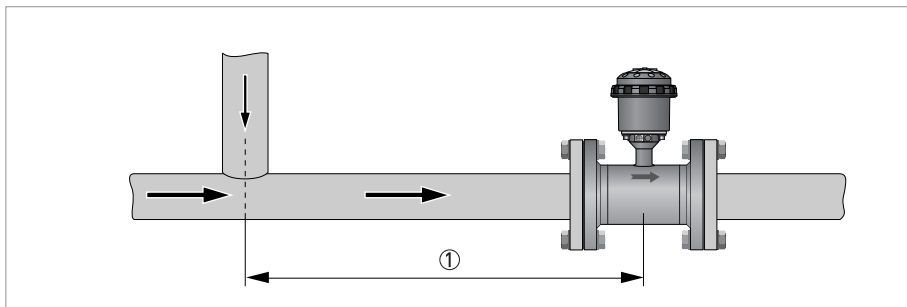

Figure 3-4: Distance behind a T-section

- ① ≥ 0 DN

3.5.3 Open feed or discharge

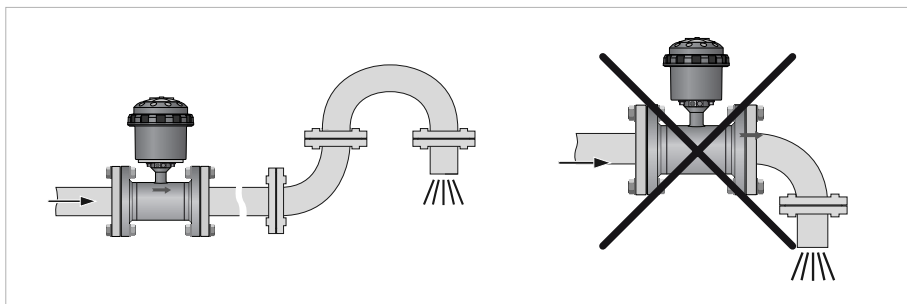

Figure 3-5: Installation in front of an open discharge

3.5.4 Bends

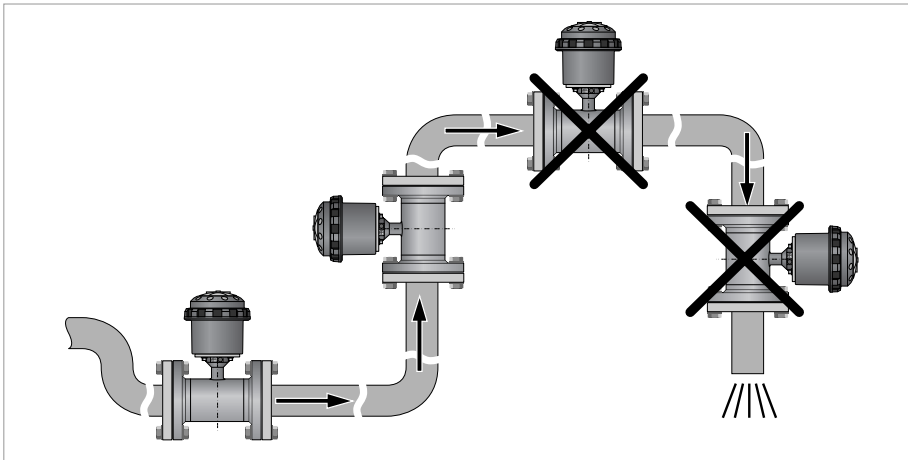

Figure 3-6: Installation in bending pipes

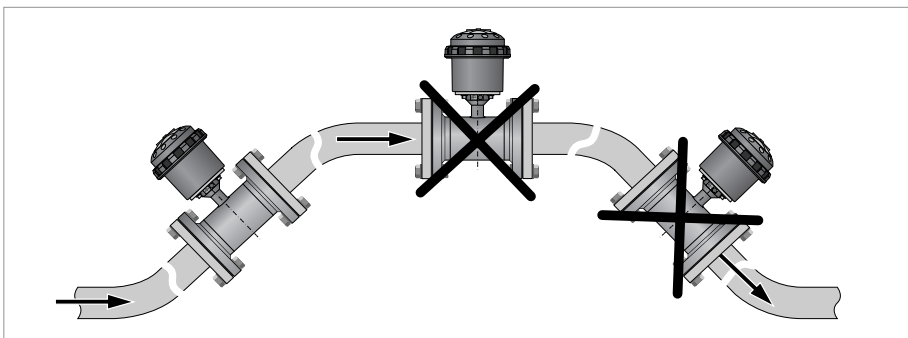

Figure 3-7: Installation in bending pipes

Avoid draining or partial filling of the flow sensor

3.5.5 Pump

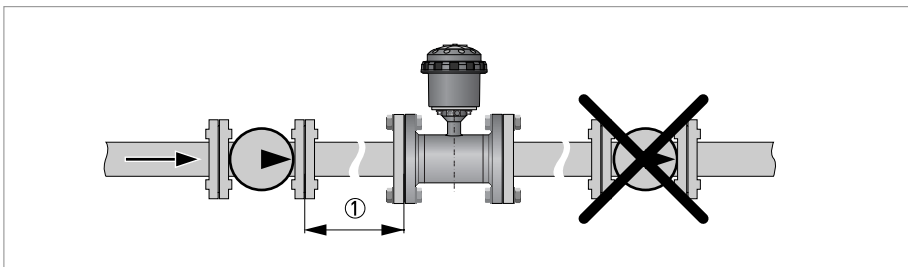

Figure 3-8: Recommended installation: behind a pump

① Inlet: ≥ 3 DN

3.5.6 Control valve

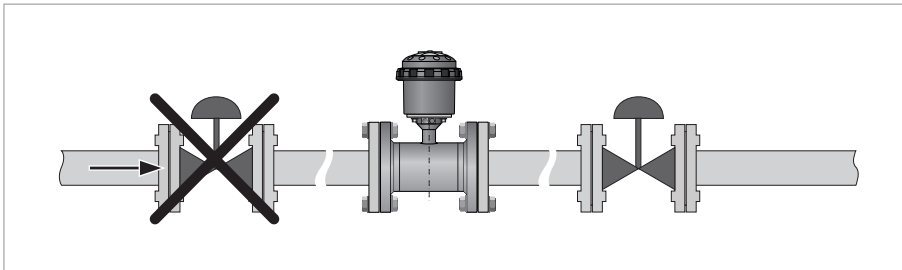

Figure 3-9: Recommended installation: in front of a control valve

3.5.7 Air venting and vacuum forces

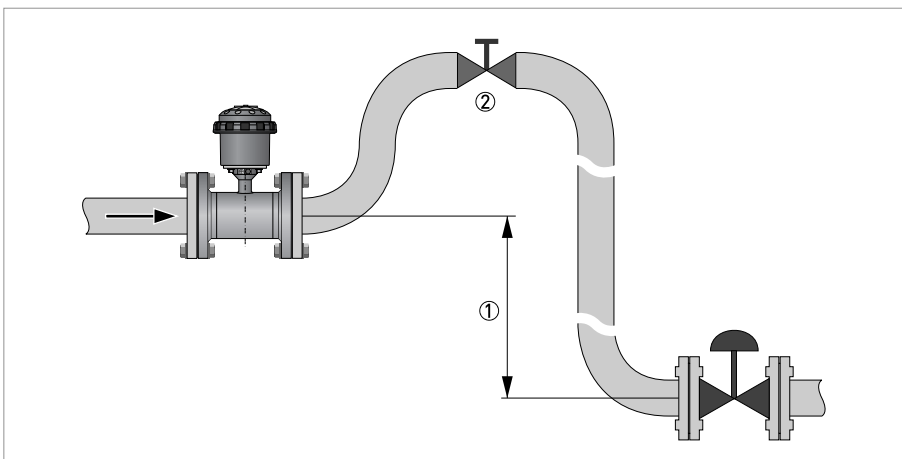

Figure 3-10: Air venting

- ① ≥ 5 m
- ② Air ventilation point

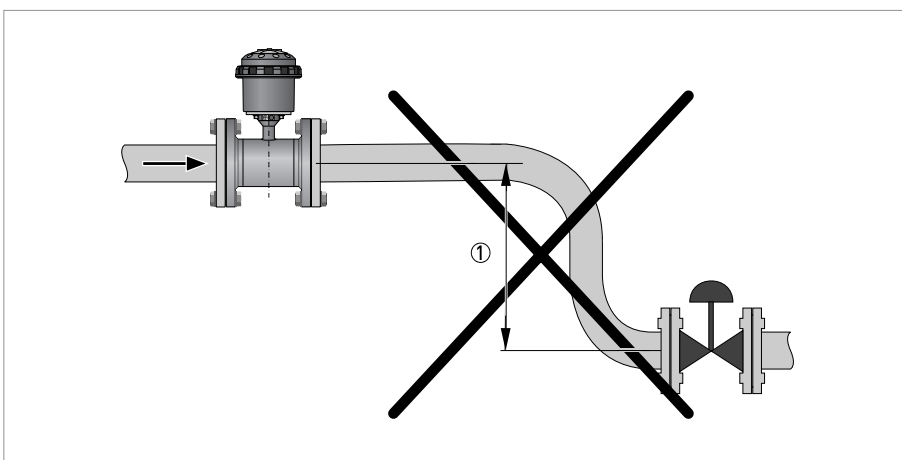

Figure 3-11: Vacuum

- ① ≥ 5 m

3.5.8 Mounting position and flange deviation

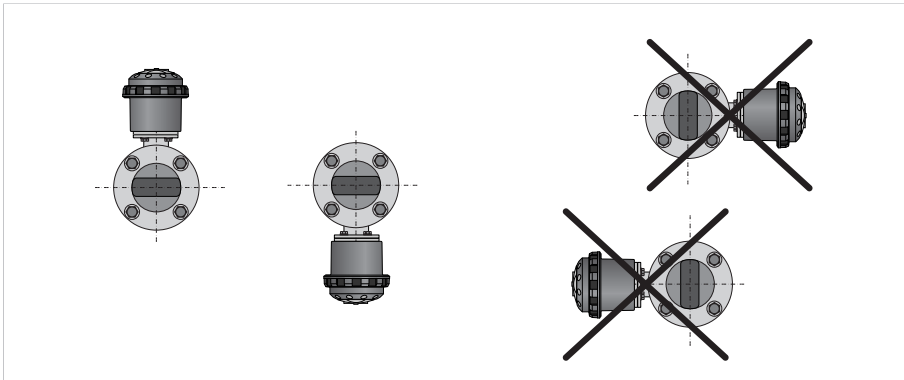

Figure 3-12: Mounting position

- Mount flow sensor either with signal converter aligned upwards or downwards.
- Install flow sensor in line with the pipe axis.
- Pipe flange faces must be parallel to each other.

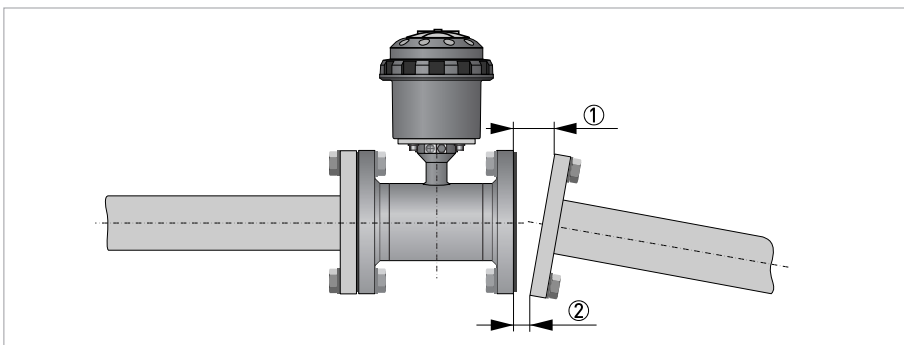

Figure 3-13: Flange deviation

- ① L_{max}
 ② L_{min}

Max. permissible deviation of pipe flange faces: $L_{max} - L_{min} \leq 0.5 \text{ mm} / 0.02''$.

Use the proper tools to ensure the integrity of the meter and prevent damage to the Rilsan® coating.

3.5.9 Installation in a metering pit and subsurface applications

The WATERFLUX 3000 flow sensor is IP68 rated (NEMA 4X/6P) to IEC60529. It is suitable for continuous submersion in flooded measurement chambers and can withstand a 10 meter water column.

The compact and remote version of the IFC 070 signal converter are IP68 rated (NEMA 4/4X/6) and suitable for periodic submersion in flooded measurement chambers. The compact and remote signal converters have a polycarbonate housing and IP68 rated (military) plug and play connectors. Submersion under water is possible down to a depth of 10 meters.

In applications with prolonged or continuous submersion, it is advised to use the WATERFLUX 3070 remote version. The remote IFC 070 signal converter and GPRS data logger unit can be installed on the wall of the measuring pit near the lid for visual read out of the display.

Submersion applications

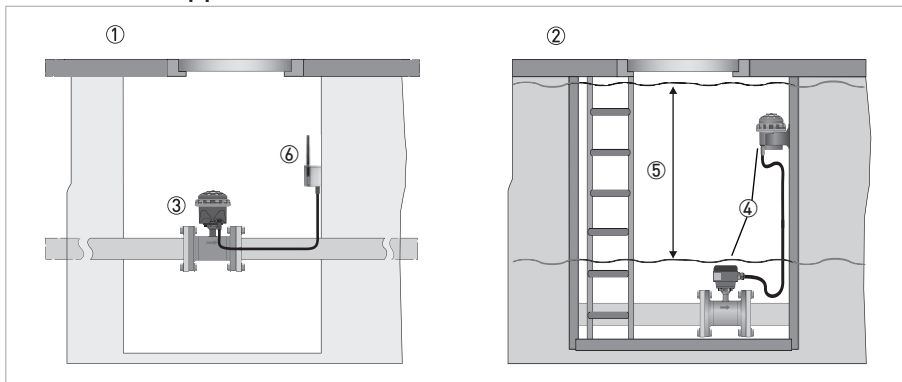

Figure 3-14: Examples of installation in measuring pit

- ① Periodic submersion
- ② Continuous submersion
- ③ WATERFLUX 3070 Compact
- ④ WATERFLUX 3070 Remote
- ⑤ Maximum water column 10 meters
- ⑥ GPRS / data logger unit

Subsurface application

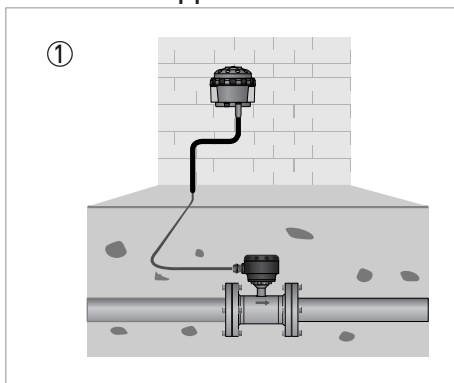

Figure 3-15: Application with buried (subsoil) sensor and a field version converter

- ① WATERFLUX 3070 remote version

Note: figures shows a cable ≤ 25 m / 82 ft

3.6 Mounting

3.6.1 Torques and pressures

The maximum pressure and torque values for the flowmeter are theoretical and calculated for optimum conditions and use with carbon steel flanges.

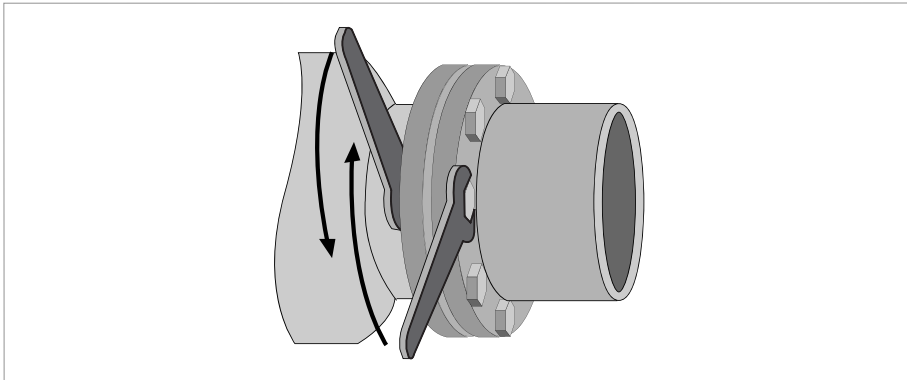

Figure 3-16: Tightening of bolts

Tightening of bolts

- Always tighten the bolts uniformly and in diagonally opposite sequence.
- Do not exceed the maximum torque value.
- Step 1: Apply approx. 50% of max. torque given in table.
- Step 2: Apply approx. 80% of max. torque given in table.
- Step 3: Apply 100% of max. torque given in table.

Nominal size DN [mm]	Pressure rating	Bolts	Max. torque [Nm] ^①
25	PN 16	4 x M 12	12
40	PN 16	4 x M 16	30
50	PN 16	4 x M 16	36
65	PN 16	8 x M 16	50
80	PN 16	8 x M 16	30
100	PN 16	8 x M 16	32
125	PN 16	8 x M 16	40
150	PN 10	8 x M 20	55
150	PN 16	8 x M 20	55
200	PN 10	8 x M 20	85
200	PN 16	12 x M 20	57
250	PN 10	12 x M 20	80
250	PN 16	12 x M 24	100
300	PN 10	12 x M 20	95
300	PN 16	12 x M 24	136
350	PN 10	16 x M 20	96
400	PN 10	16 x M 24	130
450	PN 10	20 x M 24	116
500	PN 10	20 x M 24	134
600	PN 10	20 x M 27	173

① The torque values also depend on variables (temperature, bolt material, gasket material, lubricants, etc.) outside the control of the manufacturer. Therefore these values should be regarded as indicative only.

Nominal size [inch]	Flange class [lb]	Bolts	Max. torque [lbs.ft] ^①
1	150	4 x 1/2"	4
1½	150	4 x 1/2"	11
2	150	4 x 5/8"	18
2.5	150	8 x 5/8"	27
3	150	4 x 5/8"	33
4	150	8 x 5/8"	22
5	150	8 x 3/4"	33
6	150	8 x 3/4"	48
8	150	8 x 3/4"	66
10	150	12 x 7/8"	74
12	150	12 x 7/8"	106
14	150 ②	12 x 1"	87
16	150 ②	16 x 1"	84
18	150 ②	16 x 1 1/8"	131
20	150 ②	20 x 1 1/8"	118
24	150 ②	20 x 1 1/4"	166

① The torque values also depend on variables (temperature, bolt material, gasket material, lubricants, etc.) outside the control of the manufacturer. Therefore these values should be regarded as indicative only.

② No full rating (max. 150 psi / 10 bar).

3.7 Mounting of the signal converter

Assembly materials and tools are not part of the delivery. Use the assembly materials and tools in compliance with the applicable occupational health and safety directives.

3.7.1 Remote converter housing

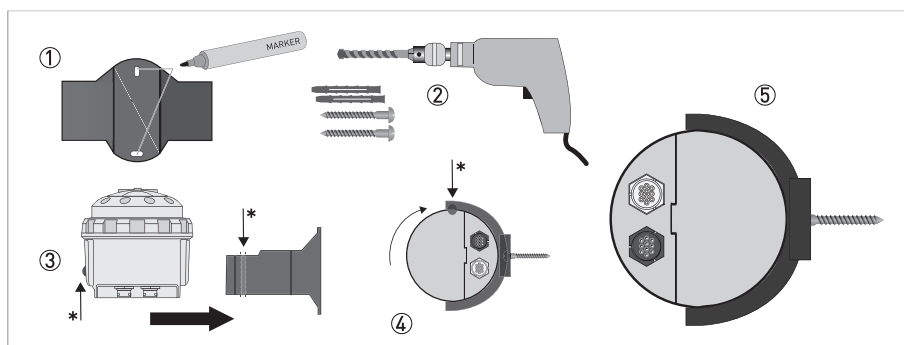

Figure 3-17: Mounting of the wall holder

- ① Mark the fixation points.
- ② Drill the holes and mount the holder with the right screws (eg. M6 x 50 with washer) and plugs.
Do not exceed a tightening torque of 2 Nm when fastening the screws. This can damage the wall holder
- ③ Slide the IP68 remote version housing into the holder as shown.
Make sure that the positioning cam * is placed in the guiding provided for that purpose (power and data connectors positioned on the backside).
- ④ Turn the housing 180° counter clockwise (until the power and data connectors are on the front side).
Make sure that the holder snaps into the lock of the wall holder.
- ⑤ Bottom view of the IP68 remote version in to the wall holder.

3.7.2 Closing of the converter housing

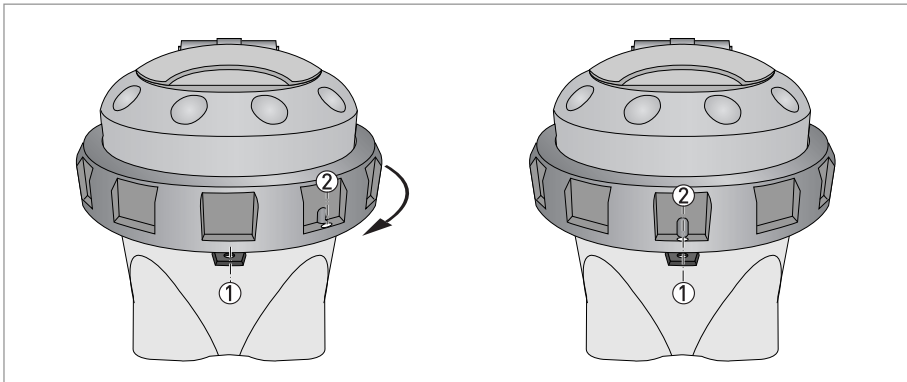

Figure 3-18: Closing of the converter housing

- Before closing the case of the converter, ensure that all surfaces in contact with the seals are clean.
- Position the upper part of the case and tighten the lock ring, up until the positions of points ① and ② are inline (do not tighten the ring any further).
- Use the special wrench to tighten the ring as advised above.
- If applicable, place a new utility seal (see section Utility Seal)

4.1 Safety instructions

All work on the electrical connections may only be carried out with the power disconnected. Take note of the voltage data on the nameplate!

Observe the national regulations for electrical installations!

Observe without fail the local occupational health and safety regulations. Any work done on the electrical components of the measuring device may only be carried out by properly trained specialists.

Look at the device nameplate to ensure that the device is delivered according to your order. Check for the correct supply voltage printed on the nameplate.

4.2 Grounding

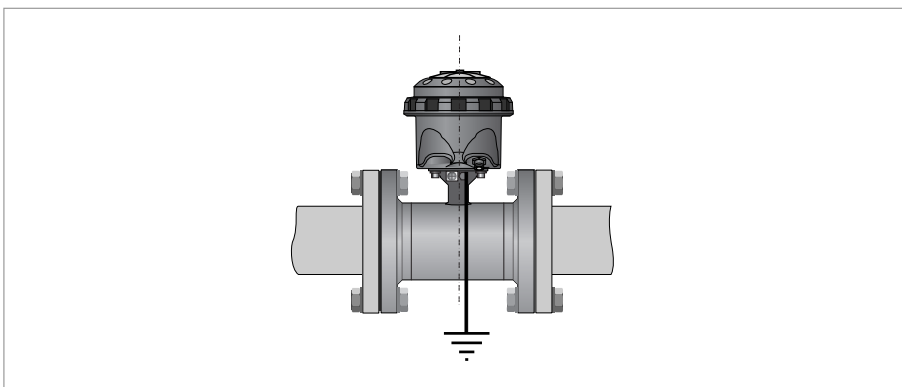

Figure 4-1: Grounding

Grounding without grounding rings. The flow sensor is equipped with a reference electrode.

4.3 Cable overview

The following overview describes the different cables available for the compact and remote version

The sensor cable for the IP68 remote (field) version has an 8 pins male connector.
The I/O cable (pulse /modbus) is available in a KROHNE FlexPower version and has an additional power cable connection.

Overview I/O cables, with or without a power cable, with female connector:

IP 68 Cable versions

I/O version	KROHNE FlexPower cable	PIN
Modbus cable	N	4
Pulse cable	N	8
KGA 42	N	8
Modbus cable	Y	10
Pulse cable	Y	8
KGA 42	Y	8

Electrical values

- **Pulse output**
2x Pulse output passive - (maximum 3 outputs possible, see status output):
 $f \leq 100 \text{ Hz}$; $I \leq 10 \text{ mA}$; $U: 2.7...24 \text{ VDC}$ ($P \leq 100 \text{ mW}$)
- **Status output**
2x Status output passive - (1 status output can be used as a third pulse output):
 $I \leq 10 \text{ mA}$; $U: 2.7...24 \text{ VDC}$ ($P \leq 100 \text{ mW}$)
- **Communication**
Modbus RTU output - (detailed information available in Supplementary Manual)
- **Optional:**
KGA external data logger / GSM module - (see the KGA 42 Supplementary Manual)

4.4 Connection of the sensor cable

The compact version of the WATERFLUX 3070 is already internally connected to the sensor and has different options to connect pulse, modbus and/or external supply cables. See the following sections for the different options and available cables.

For the WATERFLUX 3070 (F) remote version, a standard cable is delivered with the device. On the sensor side the cable is standard potted at the factory. The sensor cable has a IP68 rated RVS snap-on connection to connect the sensor with the IP68 field converter with the following color coded leads leads:

Standard sensor cable

Wire color	Terminal	Function
Brown	1	Reference electrode
White	2	Standard electrode signal
Violet	3	Standard electrode signal
Blue	7	Field current
Green	8	Field current
Yellow	9	No function
Drain wires	Screws	Shielding

The standard WSC2 sensor cable (double shielded), includes both electrode and field current leads and has a maximum length of 25 m / 82 ft. (other lengths on request).

Sensor cable with integrated P&T option

Wire color	Contact on connector	Terminal	Function
Brown	H	1	Reference electrode / P&T sensor
White	D	4	P&T sensor
Grey	F	5	P&T sensor
Pink	B	6	P&T sensor
Blue	A	7	Field current
Green	G	8	Field current
White/White	C	2	Standard electrode signal
White/Red	E	3	Standard electrode signal
Drain wires	Housing	Screws	Shielding

To ensure smooth functioning, always use the signal cables included in the delivery

4.5 Connection of the signal cable

4.5.1 IP68 housing (compact version)

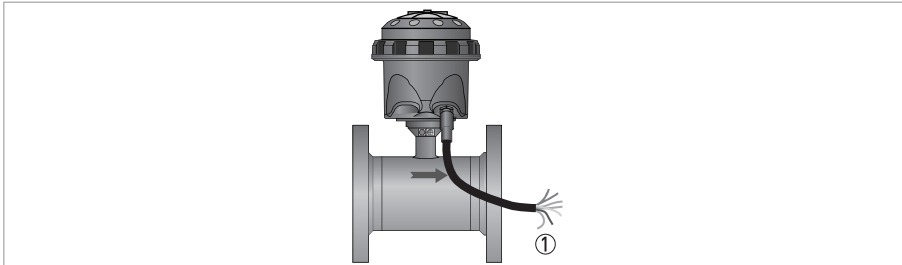

Figure 4-2: Output cable at IP68 compact version

① Color coded leads of the output cable

If an output is activated, the output cable with the IP68 rated connector has the following color coded leads:

Pulse output cable

Wire color	Contact on connector	Function
Yellow	A	Status output 1 or threshold for P or T or pulse output C
White	G	Status output 2 or threshold for P or T
Blue	H	Ground
Brown	B	Pulse output A
Green	F	Pulse output B
Pink	C	External battery +
Grey	E	External battery -

Note; with or without shielding

Modbus cable

Wire color	Contact on connector	Function
Yellow	1	Down link wire B←
Grey	1	Up link wire B→
Pink	2	Up link wire A→
Green	2	Down link wire A←
White	3	Ground
Brown	-	-
Shield	Earth	

Note: See for the combined power and modbus / pulse cable options, next chapter

4.5.2 IP68 housing (remote version)

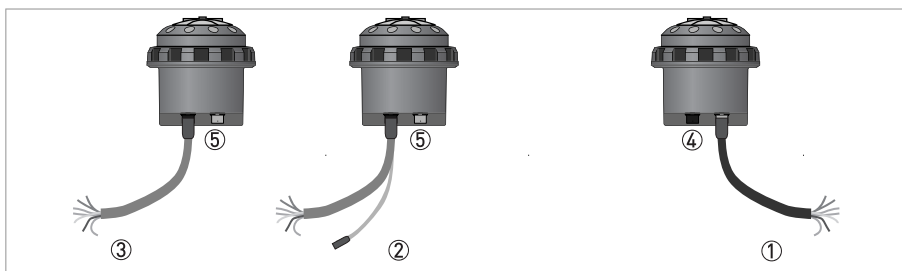

Figure 4-3: Different output cable, IP68 remote version

- ① Color coded leads of sensor cable
- ② Y - cable with additional power cable
- ③ I/O cable (pulse, modbus)
- ④ I/O connection
- ⑤ RVS sensor cable connection

Sensor cable:

refer to *Connection of the sensor cable* on page 46 for the available connection options

For connection of I/O (modbus, pulse output signals) with or without additional power supply cable connection, several cable connection options are available. The cables have the following color code leads.

Output pulse cable

Wire color	Contact on connector	Function
Yellow	A	Status output 1 or threshold for P or T or pulse output C
White	G	Status output 2 or threshold for P or T
Blue	H	Ground
Brown	B	Pulse output A
Green	F	Pulse output B
Pink	C	External battery +
Grey	E	External battery -

Modbus cable

Wire color	Contact on connector	Function
Yellow	1	Down link wire B←
Grey	1	Up link wire B→
Pink	2	Up link wire A→
Green	2	Down link wire A←
White	3	Ground
Brown	-	-
Shield	Earth	

Combined power and pulse output cable (Y-cable)

Wire color	Contact on connector	Function
Yellow	A	Status output 1 or threshold for P or T or pulse output C
White	G	Status output 2 or threshold for P or T
Grey	H	Ground
Brown	B	Pulse output A
Green	F	Pulse output B
Brown	C	External power +3.6V
White	E	External power (Ground)
Shield	D	Shielding

Combined power and Modbus cable (Y-cable)

Wire color	Contact on connector	Function
Shield	C	Shielding
Brown	B	-
White	A	Ground
Green	E	Down link wire A←
Yellow	K	Down link wire B←
Pink	H	Up link wire A→
Grey	J	Up link wire B→
Brown	F	External power +3.6V
White	G	External power (Ground)
Shield	D	Shielding

This cable has two pair of wires, one for uplink and one for downlink. Both are connected within the connector. When disconnecting the cable on the sensor side, the two paired wires will stay connected so there is disconnection of the RS-485.

Because of this connection (switching link wire), it makes no difference where the up- and downlink are connected.

For proper use and installation, it is recommended to follow the advised color coded wire connections in the table above. A 120Ω line terminator is required when the WATERFLUX 3070 converter is the last device in line and/or is part of the bus connection.

Specific information is described in the supplementary Modbus manual, available on the manufacturer website.



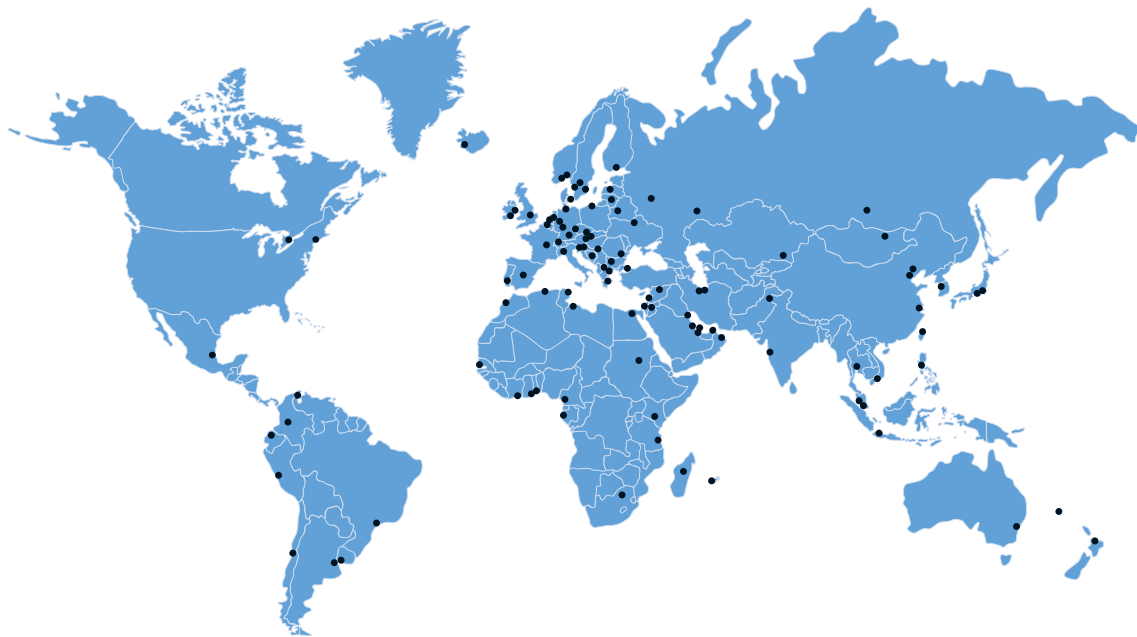

KROHNE – Process instrumentation and measurement solutions

- Flow
- Level
- Temperature
- Pressure
- Process Analysis
- Services

Head Office KROHNE Messtechnik GmbH
Ludwig-Krohne-Str. 5
47058 Duisburg (Germany)
Tel.: +49 203 301 0
Fax: +49 203 301 10389
info@krohne.com

The current list of all KROHNE contacts and addresses can be found at:
www.krohne.com

KROHNE