

Rotary Position Technology

Encoder Accessories

Spring Loaded Bracket

Part Number:
RA-SB-58

Description:
Spring loaded right angle bracket for measuring wheels and rack and pinion systems

Used with clamping flange 58 mm
face mount screws included

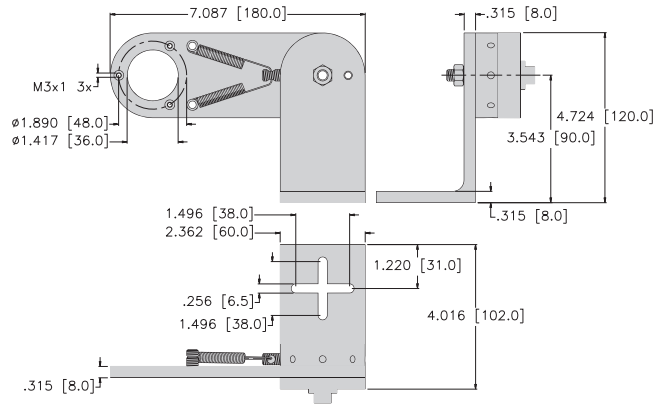

Assembly Bell

Part Number:
RA-AB-XXX-XXX

Description:
Assembly bell

Kit includes:
- Coupling
- Mounting screws

Purchase separately:
- Optional assembly with servo cleat RA-SC-58
- Used with servo flange Ø 58 mm

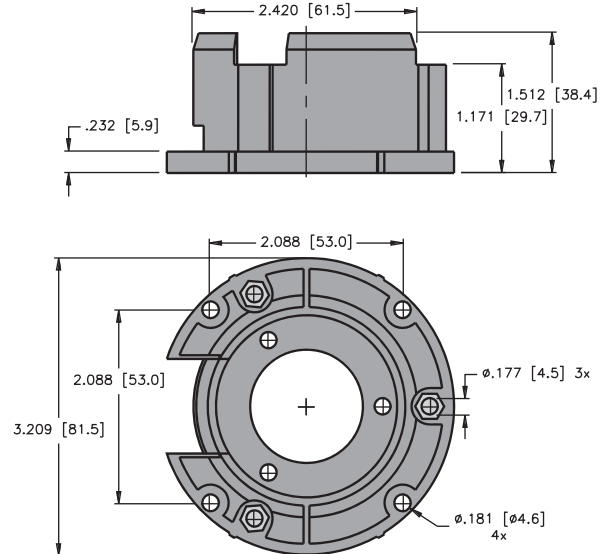

Part Number Key:
RA-AB-XXX-XXX

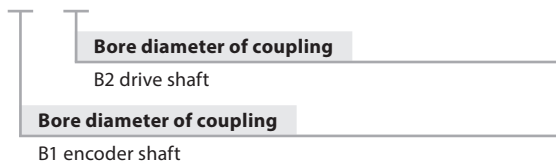

Mounting Example:

