

**Input:** -50-0 mV to 20-40 VDC, 0-200 µA to 10-50 mADC  
**Output:** 0-1 V to ±10 VDC or 0-2 mA to 4-20 mA

**Wide Ranging I/O**  
**One Minute Setup!**

- Non-Interactive Zero & Span
- One Minute Field Setup for Hundreds of I/O Ranges
- Full 2000 V Input/Output/Power Isolation
- Input and Output LoopTracker® LEDs
- Output Test Button
- Built-In Loop Power Supplies for Input and Output

**Applications**

- Convert, Boost, Rescale Process Signals
- One Model Covers Multiple Applications
- Interface Process Signals with Panel Meters, PLCs, Recorders, Data Acquisition, DCS, and SCADA Systems

**DC Input Ranges**

See table on other side for field selectable ranges. Consult factory for special ranges. System voltages must not exceed socket voltage rating

Voltage: -50-0 mVDC to 20-40 VDC  
 Bipolar voltage: ±50 mVDC to ±10 VDC  
 Current: 0-200 µADC to 10-50 mADC  
 Offset: ±100% max., ±75% max. for 40 mA input

**Input Impedance**

Voltage: 1 MΩ minimum  
 Current: 50 Ω typical  
 Input voltage burden (current) 1 VDC at 20 mA

**Common Mode Rejection**

120 dB minimum

**Input Loop Power Supply**

18 VDC nom., unregulated, 25 mADC, max. ripple, <1.5 V<sub>p-p</sub>  
 May be selectively wired for sinking or sourcing mA input

**LoopTracker**

Variable brightness LEDs indicate I/O loop level and status

**DC Output Ranges**

See table on other side for field selectable ranges. Consult factory for special ranges. Internal jumper for output reversal

Voltage, 10 mA max.: 0-1 VDC to 0-10 VDC  
 Bipolar voltage: ±1 VDC to ±10 VDC  
 Current: 0-2 mADC to 0-20 mADC  
 20 V compliance, 1000 Ω at 20 mA

**Output Calibration**

Non-interactive multi-turn zero and span potentiometers  
 ±15% of span adjustment range typical

**Output Loop Power Supply**

20 VDC nominal, regulated, 25 mADC, max. ripple <10 mVRMS

**Output Test**

Sets output to test level when pressed. Adjustable 0-100% of span. Potentiometer factory set to approx. 50% of span.

**Output Ripple and Noise**

Less than 10 mVRMS

**Linearity**

Better than ±0.1% of span

**Ambient Temperature Range and Stability**

-10°C to +60°C operating ambient  
 Better than ±0.02% of span per °C stability

**Response Time**

70 milliseconds typical  
 DF option: 5 millisecond typical response time

**Isolation**

2000 VRMS minimum  
 Full isolation: power to input, power to output, input to output

**Installation Environment**

IP 40, requires installation in panel or enclosure  
 Use with API 008 or API 008 FS socket  
 Socket mounts to 35 mm DIN rail or can be surface mounted  
 UL 508C pollution degree 2 environments or better

**Power**

Standard: 115 VAC ±10%, 50/60 Hz, 2.5 W max.  
 P option: 85-265 VAC 50/60 Hz, 60-300 VDC, 2.5 W  
 A230 option: 230 VAC ±10%, 50/60 Hz, 2.5 W max.  
 D option: 9-30 VDC, 2.5 W typical

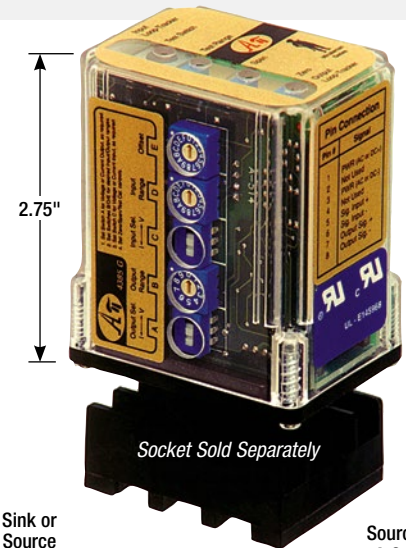
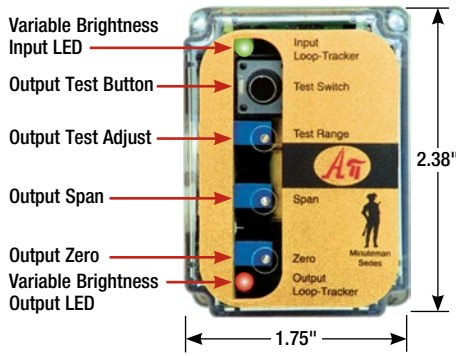

115 VAC, 230 VAC models

[Quick Link  
api-usa.com/4385](http://api-usa.com/4385)

**Description**

The API 4385 G accepts a DC voltage or current input and provides an optically isolated DC voltage or current output that is linearly related to the input. Typical applications include signal isolation, signal conversion, signal boosting or a combination of the three.

The optical isolation between input and output makes this module useful for ground loop elimination, common mode signal rejection or noise pickup reduction. The module power supply is isolated, resulting in full 3-way (input, output, power) isolation.

The API 4385 G input, output and zero offset can be field-configured via external rotary and slide switches. Zero offset is adjustable in 15% increments to a maximum of ±100% of span. Common range settings are on the module label. Non-interactive zero and span adjustments simplifies calibration. Output reversal (4-20 mA input to 20-4 mA output) can be changed via an internal jumper.

The built-in 18 VDC unregulated loop excitation power supply can be used to power passive input devices.

**LoopTracker**

API exclusive features include two LoopTracker LEDs (green for input, red for output) that vary in intensity with changes in the process input and output signals. These provide a quick visual picture of your process loop at all times and can greatly aid in saving time during initial startup and/or troubleshooting.

**Output Test**



An API exclusive feature includes the Functional Test Button to provide a fixed output (independent of the input) when held depressed. The test output level can be set via a potentiometer from 0 to 100% of the output span.

The functional test button greatly aids in saving time during initial startup and/or troubleshooting.

**Installation**

The API 4385 G plug into an industry standard 8-pin octal socket sold separately. Sockets API 008 and finger-safe API 008 FS allow either DIN rail or panel mounting.

The plug-in design, 3-way isolation, and robust electronics allows the module to be quickly hot-swapped without removing the power or I/O signals.

Model	Input	Output	Power
API 4385 G	Field configurable Specify input range if factory is to set switches	Field configurable Specify output range if factory is to set switches	115 VAC 
API 4385 G A230			230 VAC 
API 4385 G P			85-265 VAC or 60-300 VDC
API 4385 G D			9-30 VDC

**Free Factory Setup**

Specify I/O ranges if factory is to set switches

**Options—add to end of model number**

- M01** I/O reversal, such as 4-20 mA in to 20-4 mA out
- DF** 5 millisecond response time, or consult factory  
DF option will cause output noise levels greater than standard specifications.
- U** Conformal coating for moisture resistance

**Accessories—order as separate line item**

- API 008** 8-pin socket
- API 008 FS** 8-pin finger-safe socket
- API CLP1** Module hold-down spring for high vibration or mobile applications



API 008 FS  
300 V Rating



API 008  
600 V Rating



API CLP1

## Precautions

**WARNING!** All wiring must be performed by a qualified electrician or instrumentation engineer. See diagram for terminal designations and wiring examples. Consult factory for assistance.

**WARNING!** Avoid shock hazards! Turn signal input, output, and power off before connecting or disconnecting wiring, or removing or installing module.

## Précautions

**ATTENTION!** Tout le câblage doit être effectué par un électricien ou ingénieur en instrumentation qualifié. Voir le diagramme pour désignations des bornes et des exemples de câblage. Consulter l'usine pour assistance.

**ATTENTION!** Éviter les risques de choc! Fermez le signal d'entrée, le signal de sortie et l'alimentation électrique avant de connecter ou de déconnecter le câblage, ou de retirer ou d'installer le module.

API maintains a constant effort to upgrade and improve its products. Specifications are subject to change without notice. See [api-usa.com](http://api-usa.com) for latest product information. Consult factory for your specific requirements.

**WARNING:** This product can expose you to chemicals including lead and nickel, which are known to the State of California to cause cancer or birth defects or other reproductive harm. For more information go to [www.P65Warnings.ca.gov](http://www.P65Warnings.ca.gov)

## Socket and Mounting

Install module in a protective panel or enclosure. Allow space around module for air flow. Use API 008 or API 008 FS socket. See specifications for maximum allowable socket voltages. The socket clips to a standard 35 mm DIN rail or can be mounted to a flat surface.

## Range Selection

Set I/O ranges first with the three rotary switches and two slide switches on the side of the module. Popular ranges are listed on the module label.

1. Set the **Output Select** slide switch **A** to current (I) or voltage (V) depending on output type.
2. Set the **Input Select** slide switch **C** to current (I) or voltage (V) depending on input type. This determines the input impedance for the module, typically 50 Ω for current inputs and 1 MΩ or greater for voltage inputs.
3. From the range table, find the rotary switch combination that matches your input and output ranges.
4. Set the three rotary switches **B**, **D**, and **E** to the values found in the table that match your input and output ranges.
5. Proceed to Calibration and Output Test Function setup.

## Additional Ranges

The table at the bottom right can be used to set up special ranges. For example, if a 1-10 V input is required:

- Set the Input Select switch to V.
- Set switch **D** to position C = 10 V.
- Set switch **E** to position 1 = +15% offset.
- This will create an input range of 1.5 V to 11.5 V.
- Use the zero and span potentiometers to calibrate output to desired range.

Output	0-1V	0-2V	0-4V	1-5V	0-5V	0-8V	2-10V	0-10V	±5V	±10V	0-2mA	2-10mA	0-10mA	0-16mA	4-20mA	0-20mA
Switches Input	BDE	BDE	BDE	BDE	BDE	BDE	BDE	BDE	BDE	BDE	BDE	BDE	BDE	BDE	BDE	BDE
0-200 µA	020	820	120	620	920	220	720	320	420	520	020	620	920	220	720	320
0-1 mA	060	860	160	660	960	260	760	360	460	560	060	660	960	260	760	360
0-2 mA	000	800	100	600	900	200	700	300	400	500	000	600	900	200	700	300
0-4 mA	010	810	110	610	910	210	710	310	410	510	010	610	910	210	710	310
0-8 mA	080	880	180	680	980	280	780	380	480	580	080	680	980	280	780	380
0-10 mA	040	840	140	640	940	240	740	340	440	540	040	640	940	240	740	340
0-16 mA	090	890	190	690	990	290	790	390	490	590	090	690	990	290	790	390
4-20 mA	09A	89A	19A	69A	99A	29A	79A	39A	49A	59A	09A	69A	99A	29A	79A	39A
0-20 mA	050	850	150	650	950	250	750	350	450	550	050	650	950	250	750	350
10-50 mA	0CA	8CA	1CA	6CA	9CA	2CA	7CA	3CA	4CA	5CA	0CA	6CA	9CA	2CA	7CA	3CA
-50-0 mV	02F	82F	12F	62F	92F	22F	72F	32F	42F	52F	02F	62F	92F	22F	72F	32F
0-50 mV	020	820	120	620	920	220	720	320	420	520	020	620	920	220	720	320
0-100 mV	030	830	130	630	930	230	730	330	430	530	030	630	930	230	730	330
0-200 mV	0A0	8A0	1A0	6A0	9A0	2A0	7A0	3A0	4A0	5A0	0A0	6A0	9A0	2A0	7A0	3A0
0-250 mV	060	860	160	660	960	260	760	360	460	560	060	660	960	260	760	360
0-400 mV	0B0	8B0	1B0	6B0	9B0	2B0	7B0	3B0	4B0	5B0	0B0	6B0	9B0	2B0	7B0	3B0
0-500 mV	000	800	100	600	900	200	700	300	400	500	000	600	900	200	700	300
0-1 V	010	810	110	610	910	210	710	310	410	510	010	610	910	210	710	310
0-2 V	080	880	180	680	980	280	780	380	480	580	080	680	980	280	780	380
0-2.5 V	040	840	140	640	940	240	740	340	440	540	040	640	940	240	740	340
0-5 V	050	850	150	650	950	250	750	350	450	550	050	650	950	250	750	350
1-5 V	09A	89A	19A	69A	99A	29A	79A	39A	49A	59A	09A	69A	99A	29A	79A	39A
±5 V	0C3	8C3	1C3	6C3	9C3	2C3	7C3	3C3	4C3	5C3	0C3	6C3	9C3	2C3	7C3	3C3
0-10 V	0C0	8C0	1C0	6C0	9C0	2C0	7C0	3C0	4C0	5C0	0C0	6C0	9C0	2C0	7C0	3C0
±10 V	0D3	8D3	1D3	6D3	9D3	2D3	7D3	3D3	4D3	5D3	0D3	6D3	9D3	2D3	7D3	3D3
0-20 V	0D0	8D0	1D0	6D0	9D0	2D0	7D0	3D0	4D0	5D0	0D0	6D0	9D0	2D0	7D0	3D0
20-40 V	0DF	8DF	1DF	6DF	9DF	2DF	7DF	3DF	4DF	5DF	0DF	6DF	9DF	2DF	7DF	3DF

## Signal Input

Polarity must be observed when connecting the signal input. If your transmitter has a current output and provides power to the current

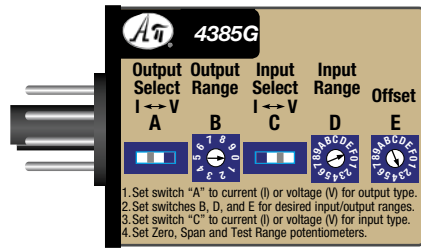

loop, wire the device to terminals 6 and 5. Use a multi-meter to confirm voltage at the transmitter output terminals. Typical voltage may be in the range of 9 to 24 VDC.

A passive input device can be powered by the 18 volt DC power supply at terminal 4. See wiring diagram for example.

## Signal Output

Polarity must be observed for output wiring connections. If the output does not function, check wiring and polarity.

When set up for current output (switch **A** to I), the output current loop will be powered by the API module.

## Module Power

AC power is connected to terminals 1 and 3. For DC powered modules (D option), polarity **MUST** be observed. Positive (+) is wired to terminal 1 and negative (-) is wired to terminal 3.

## Calibration

Input and output ranges, if specified on your order, are factory pre-configured (at 24°C ±1°C). Top-mounted Zero and Span potentiometers calibrate the output.

Note: Perform the following calibration procedure any time switch settings are changed.

1. Apply power to the module and allow a minimum 20 minute warm up time.
2. Using an accurate calibration source, provide an input to the module equal to the minimum input required for the application.
3. Using an accurate measurement device for the output, adjust the Zero potentiometer for the exact minimum output desired. The Zero control should only be adjusted when the input signal is at its minimum. This will produce the corresponding minimum output signal. For example: 4 mA for a 4-20 mA output or -10 V for a ±10V output.
4. Next, set the input at maximum, then adjust the Span pot for the exact maximum output desired. The Span control should only be adjusted when the input signal is at its maximum. This will produce the corresponding maximum output signal. Example:

for 4-20 mA output, the Span control will provide adjustment for the 20 mA or high end of the signal.

5. Repeat adjustments for maximum accuracy.

## Output Test Function

The Test button may be pushed to provide a fixed output when depressed. This will drive the device on the output side of the loop (a panel meter, chart recorder, etc.) with a known good signal that can be used as a system diagnostic aid during initial start-up or during troubleshooting. It can be adjusted to vary the output signal from 0 to 100% of the calibrated output range. When released, the output will return to normal.

Turn the multi-turn Test Range potentiometer while holding the Test Switch depressed until the desired output test level is reached.

## Operation

The API 4385 G input is filtered, either amplified or attenuated as required, then passed through an optical isolation circuit to the output stage.

The green LoopTracker® input LED provides a visual indication that a signal is being sensed by the input circuitry of the module. It also indicates the input signal strength by changing in intensity as the process changes from minimum to maximum.

If the LED fails to illuminate, or fails to change in intensity as the process changes, check the module power or signal input wiring. Note that it may be difficult to see the LEDs under bright lighting conditions.

The red LoopTracker output LED provides a visual indication that the output signal is functioning. It becomes brighter as the input and the corresponding output change from minimum to maximum.

For a current output, the red LED will only light if the output loop current path is complete. For either current or voltage outputs, failure to illuminate or a failure to change in intensity as the process changes may indicate a problem with the module power or signal output wiring.

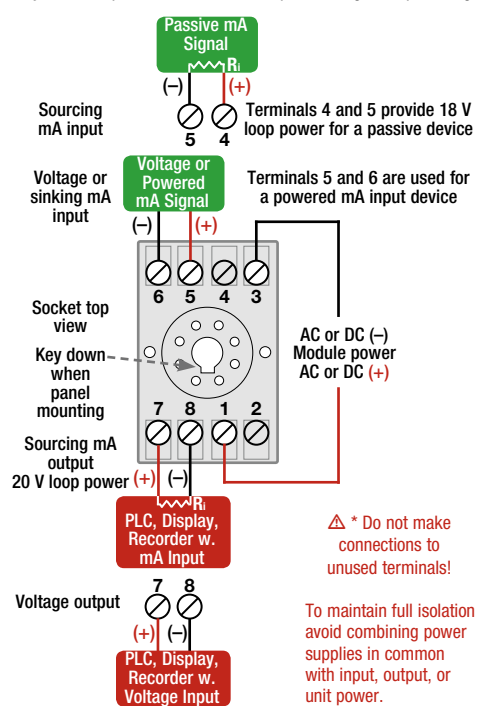

API 4385 G User-Set Special Ranges									
Output Range			Input Span			Input Offset			
Voltage	Current	Sw.	Voltage	Current	Sw.	Voltage	Input Span %	Sw.	E
0-1 V	0-2 mA	0	50 mV	200 µA	2	+100%	7		
0-2 V	0-4 mA	8	100 mV	400 µA	3	+90%	6		
0-4 V	0-8 mA	1	200 mV	800 µA	A	+75%	5		
0-5 V	0-10 mA	9	250 mV	1 mA	6	+60%	4		
0-8 V	0-16 mA	2	400 mV	1.6 mA	B	+45%	3		
0-10 V	0-20 mA	3	500 mV	2 mA	0	+30%	2		
1-5 V	2-10 mA	6	1 V	4 mA	1	+15%	1		
2-10 V	4-20 mA	7	2 V	8 mA	8	0%	0, 8		
±5 V		4	2.5 V	10 mA	4	-15%	9		
±10 V		5	4 V	16 mA	9	-30%	A		
For ranges that are in between listed ranges set to the next highest range and trim with zero and span pots.			5 V	20 mA	5	-45%	B		
			10 V	40 mA*	C	-60%	C		
			20 V		D	-75%	D		
* Max. allowable offset ±75% for 40 mA							-90%	E	
							-100%	F	